

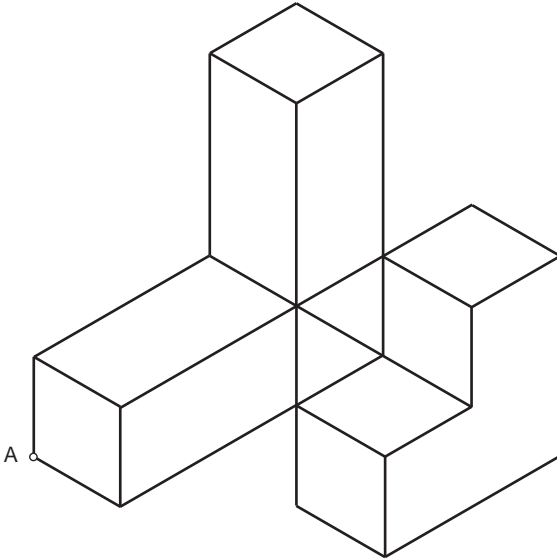

Las figuras dadas están representadas en el Sistema Isométrico a escala 1:1 y sin coeficiente de reducción. Dibujarlas a la misma escala en el Sistema Diédrico (Método Directo), tomando como referencia el punto dado A. Representar también las partes vistas y ocultas.

1



a' o

a o

2

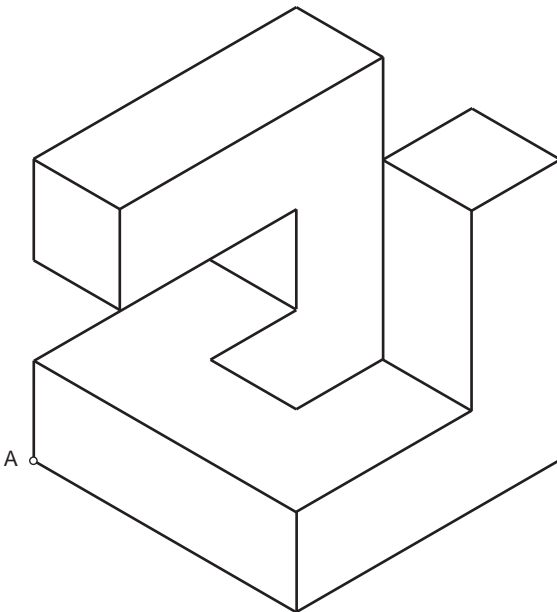

a' o

a o

ALUMNO:

ESPECIALIDAD:

NÚMERO:



1

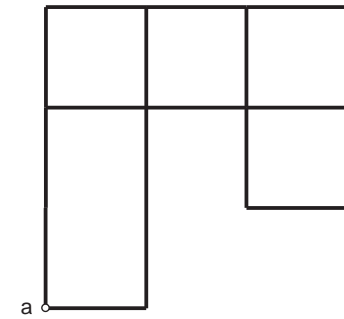
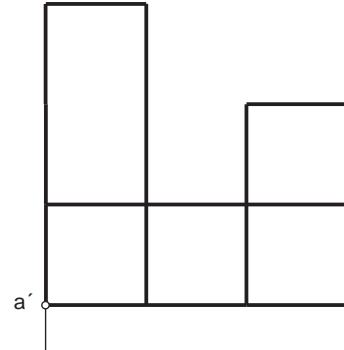
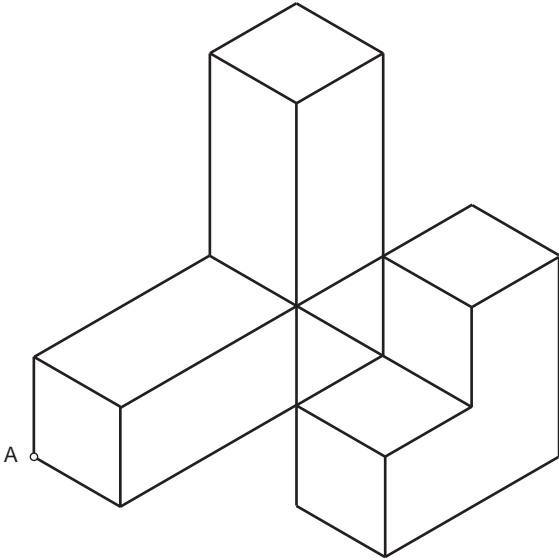

2

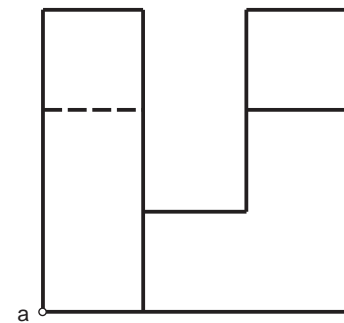
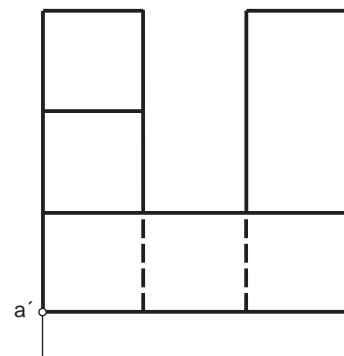
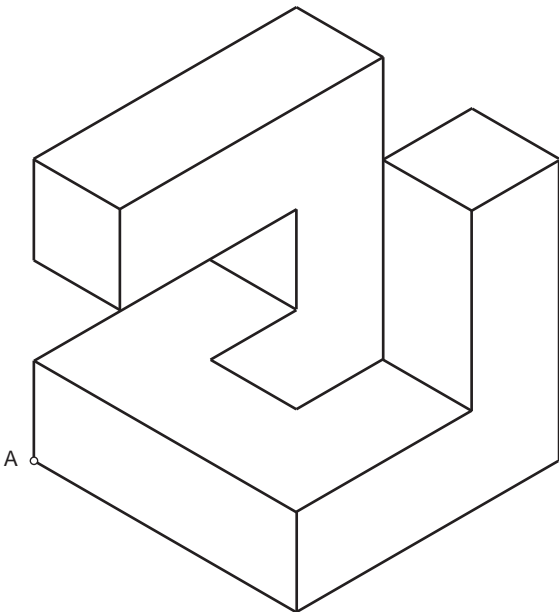



Las figuras dadas están representadas en el Sistema Isométrico a escala 1:1 y sin coeficiente de reducción. Dibujarlas a la misma escala en el Sistema Diédrico (Método Directo), tomando como referencia el punto dado O y sin representar partes ocultas.

1

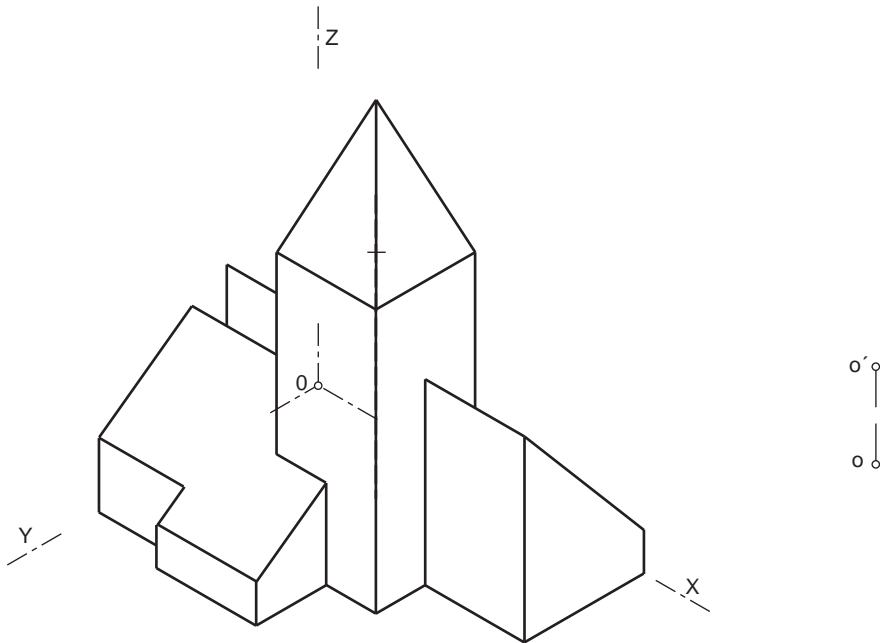

2

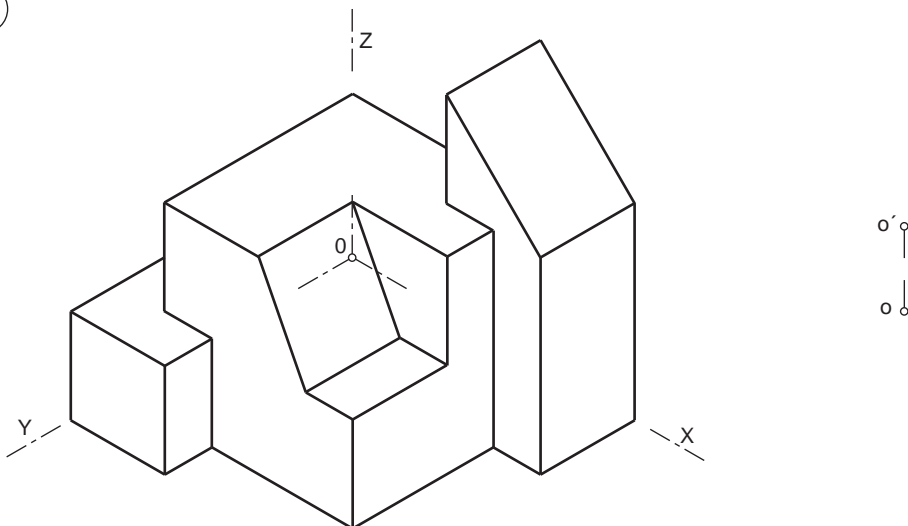

ALUMNO:

ESPECIALIDAD:

NÚMERO:



1

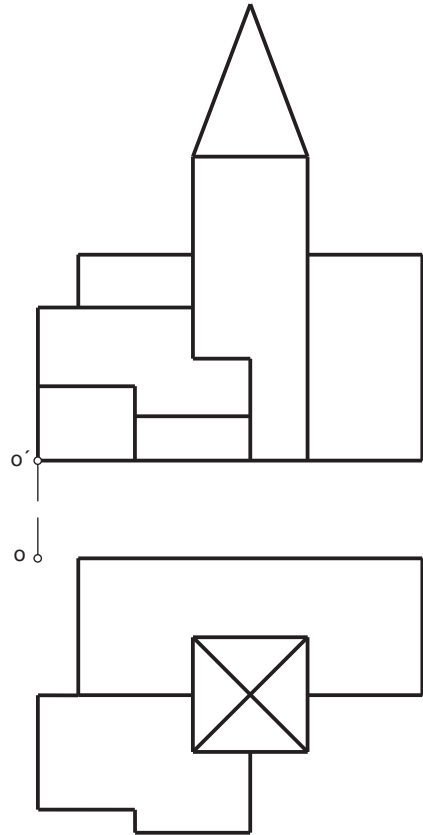
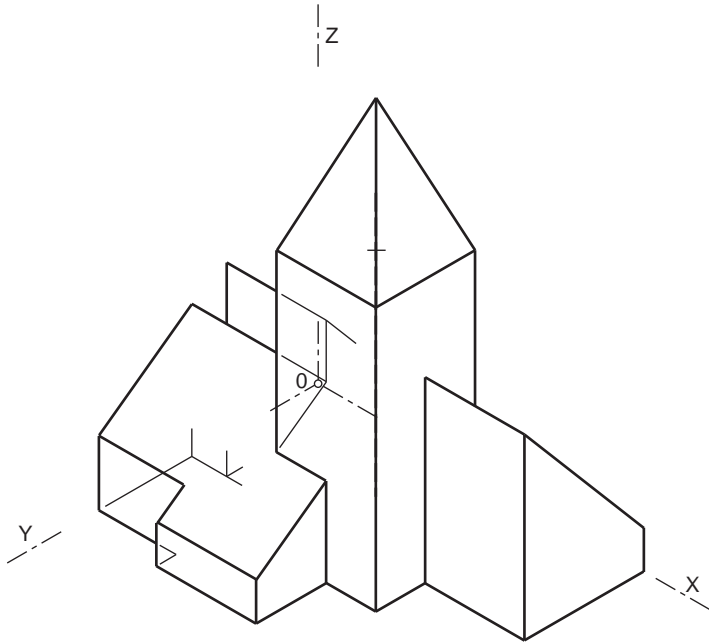

2

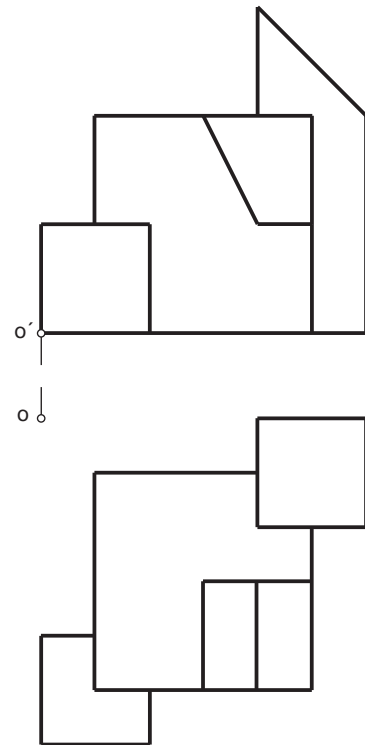
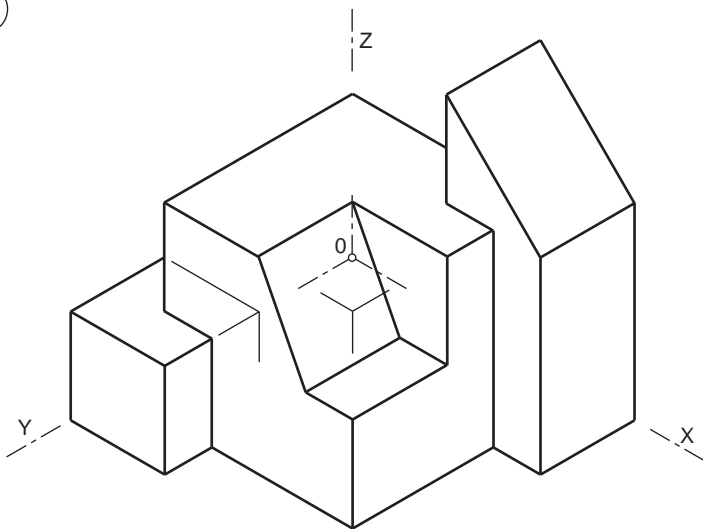



Las figuras dadas están representadas en el Sistema Isométrico a escala 1:1 y sin coeficiente de reducción. Dibujarlas a la misma escala en el Sistema Diédrico (Método Directo), tomando como referencia el punto dado A. Representar también las partes ocultas.

1

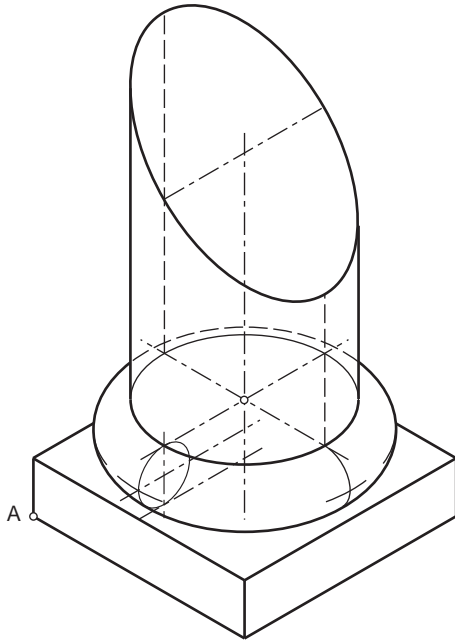

a' o

a o

2

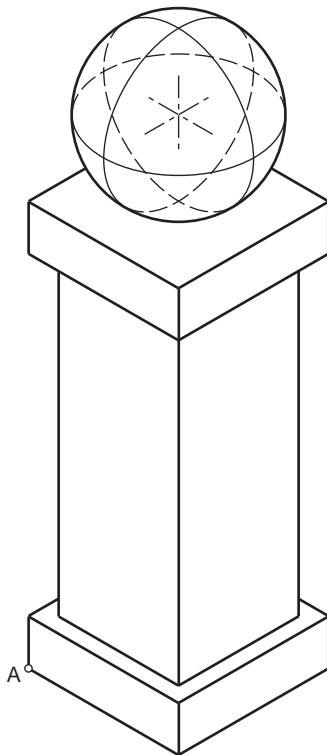

a' o

a o

ALUMNO:

ESPECIALIDAD:

NÚMERO:



1

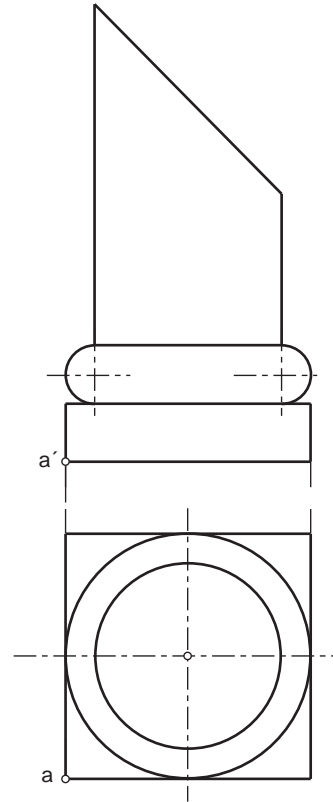
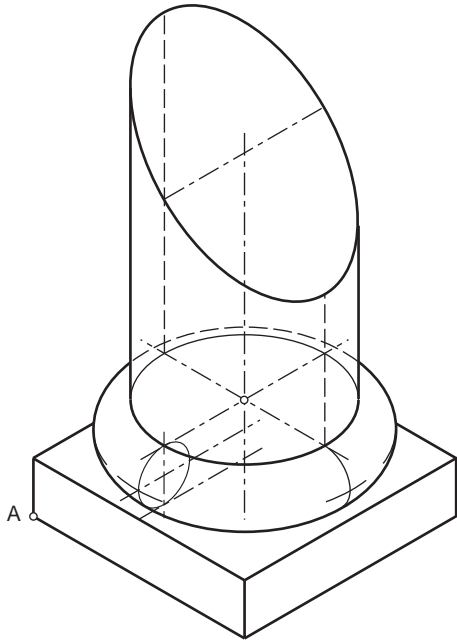

2

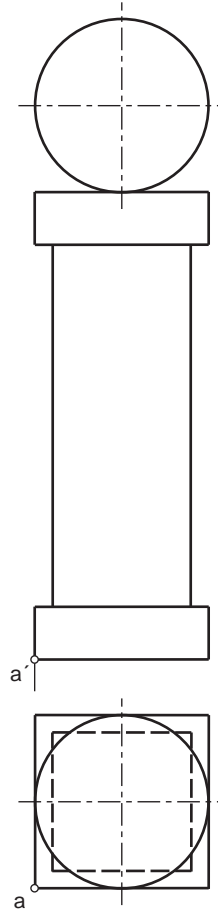
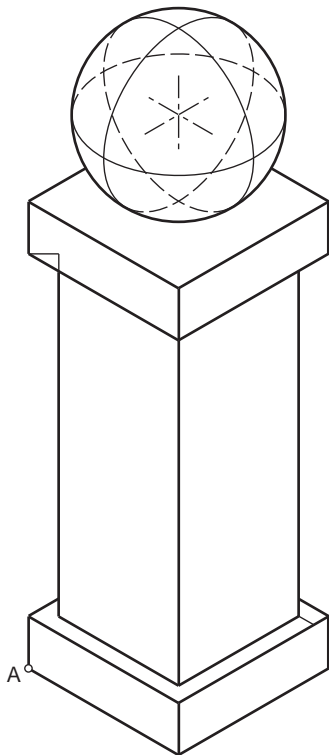



Las figuras dadas están representadas en el Sistema Isométrico a escala 1:1 y sin coeficiente de reducción. Dibujarlas a la misma escala en el Sistema Diédrico (Método Directo), tomando como referencia el punto dado A. Representar también las partes ocultas.

1

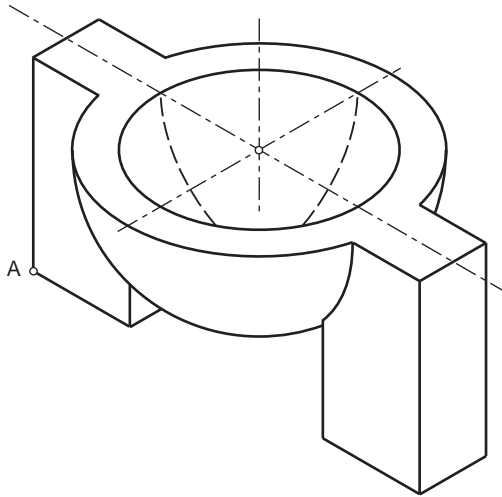

a' o

a o

2

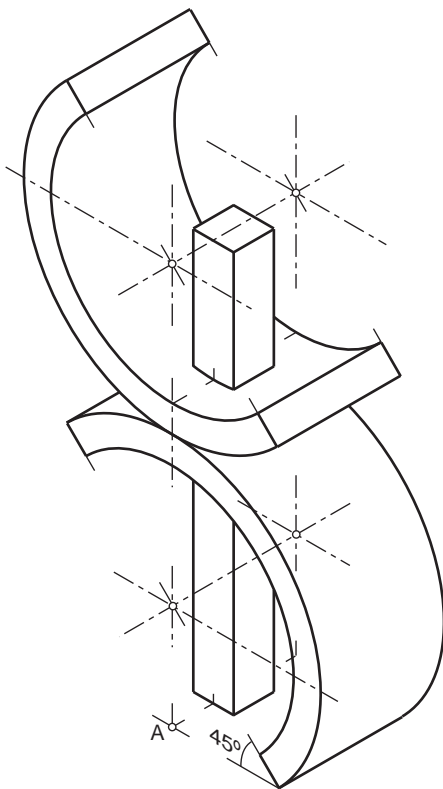

a' o

a o

ALUMNO:

ESPECIALIDAD:

NÚMERO:



1

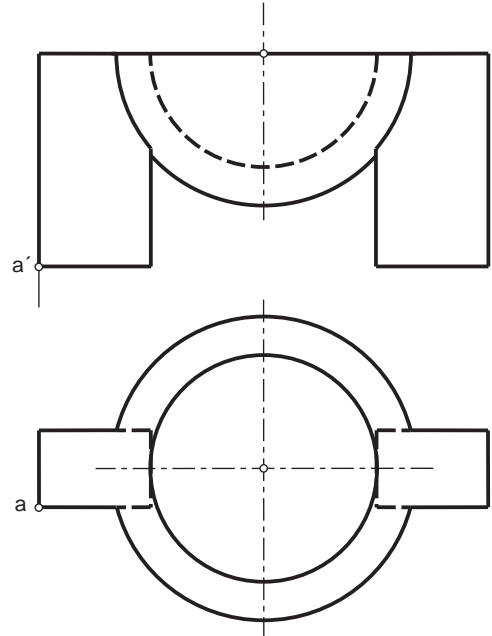
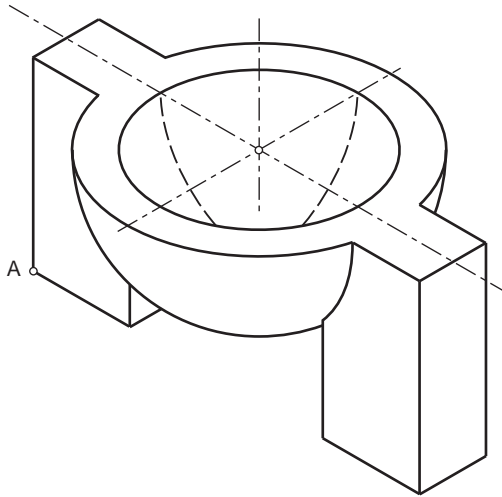

2

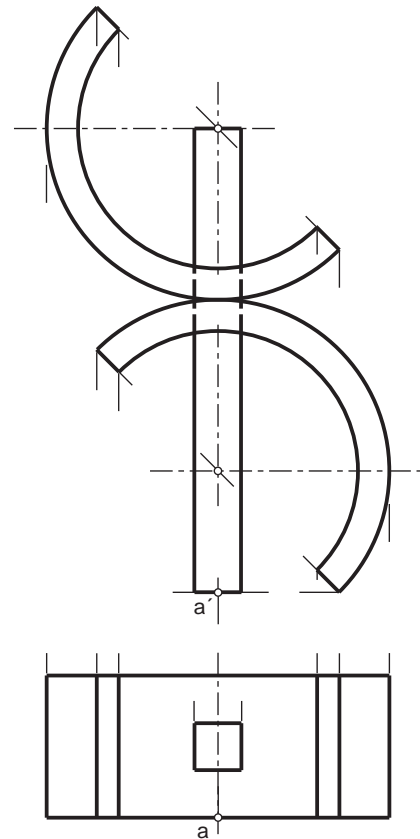
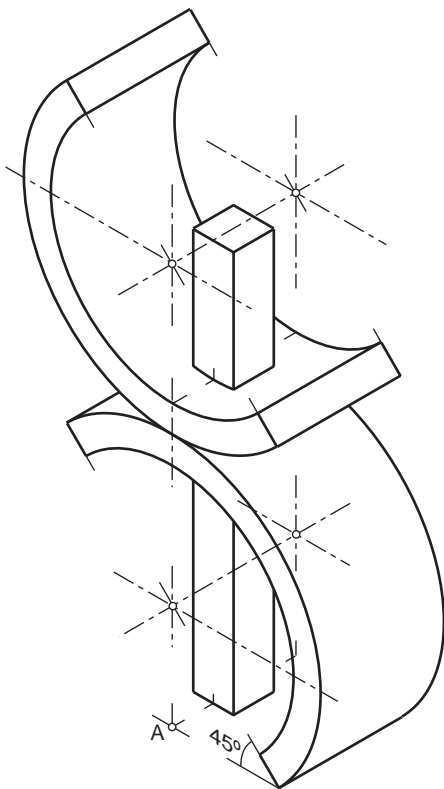



Las figuras dadas están representadas en el Sistema Isométrico a escala 1:1 y sin coeficiente de reducción. Dibujarlas a la misma escala en el Sistema Diédrico (Método Directo), tomando como referencia el punto dado O, origen de los sistemas.

1

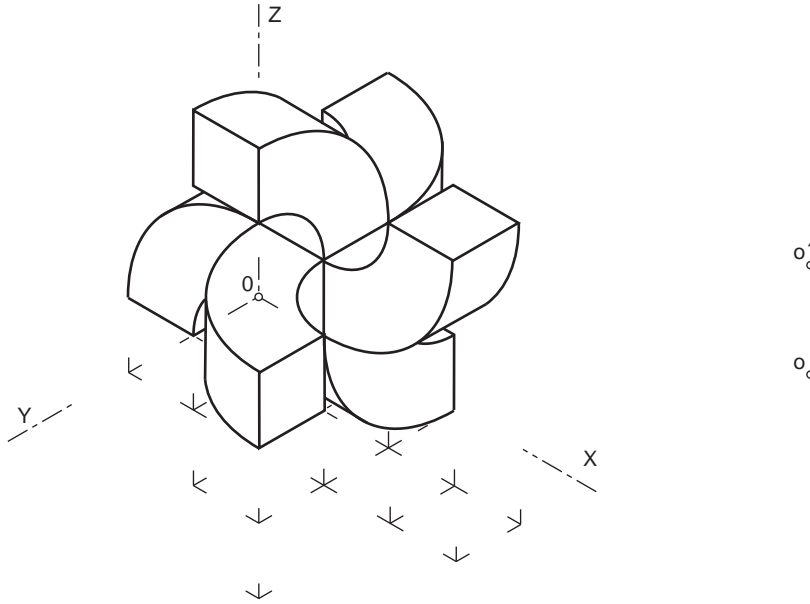

2

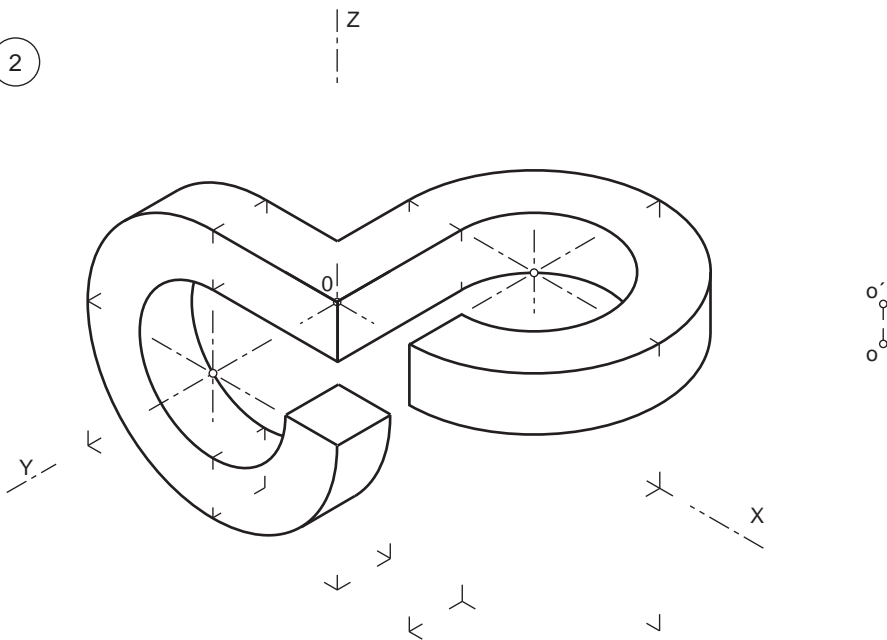

ALUMNO:

ESPECIALIDAD:

NÚMERO:



1

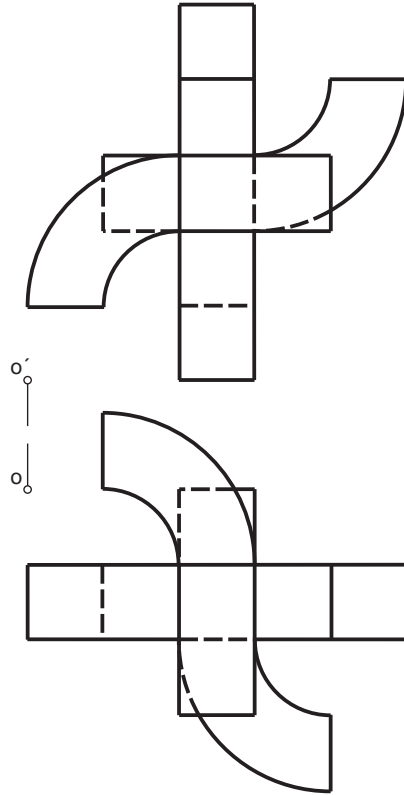
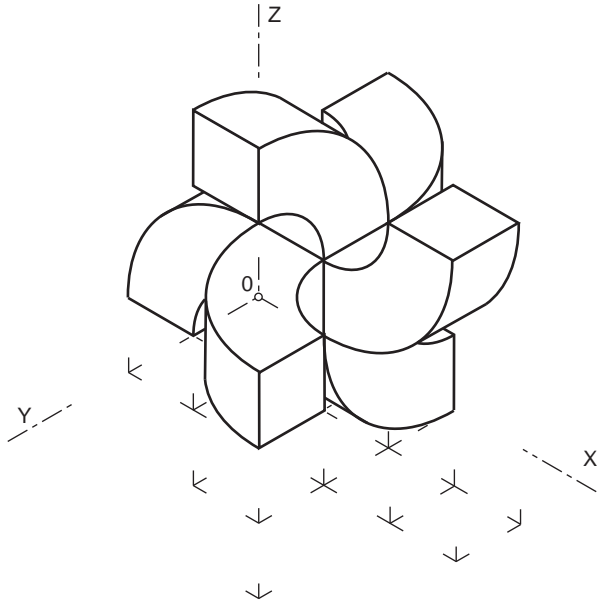

2

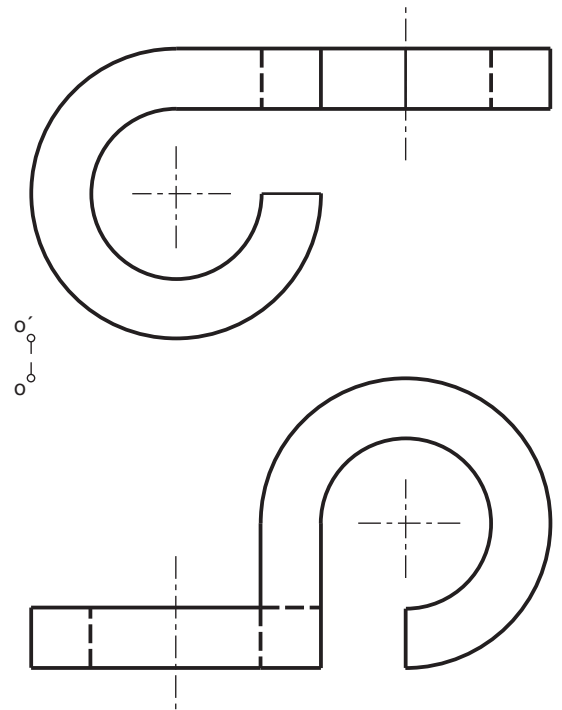
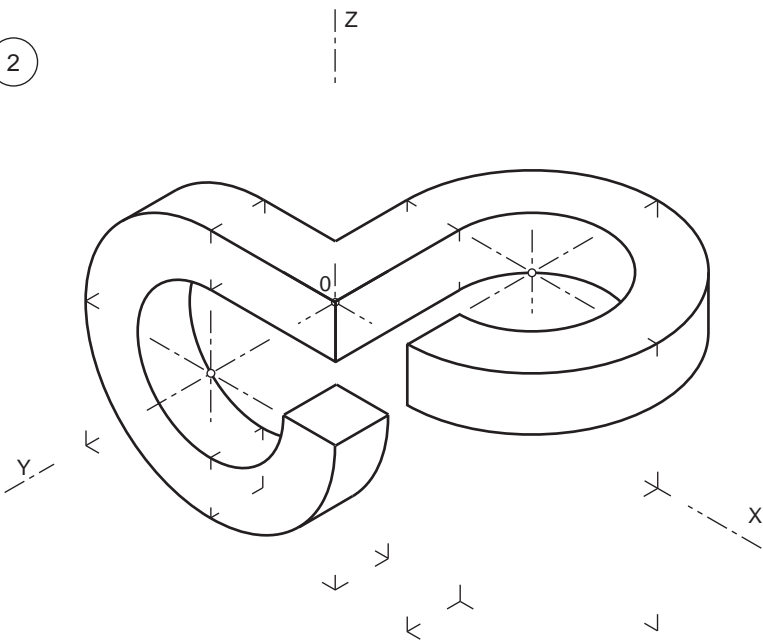



Las figuras dadas están representadas en Perspectiva Caballera a escala 1:1 y con un coeficiente de reducción para el eje Y de 0,5. Dibujarlas a la misma escala en el Sistema Diédrico (Método Directo), tomando como referencia el punto dado O y sin representar partes ocultas.

1

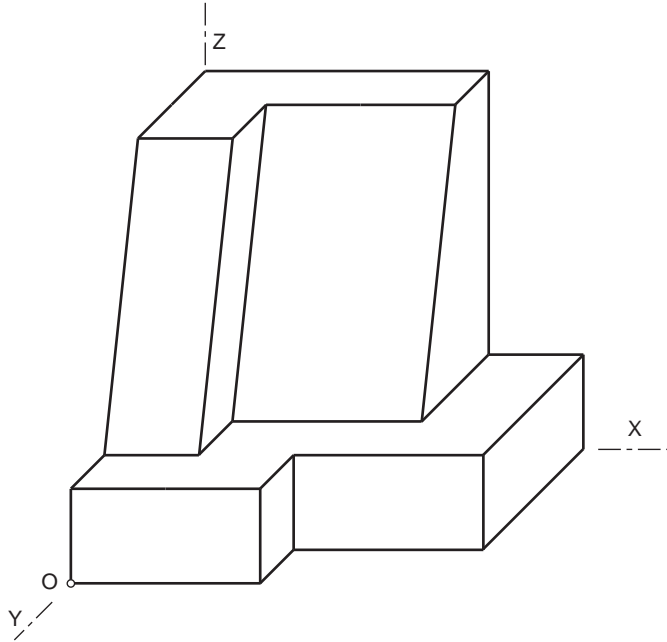

2

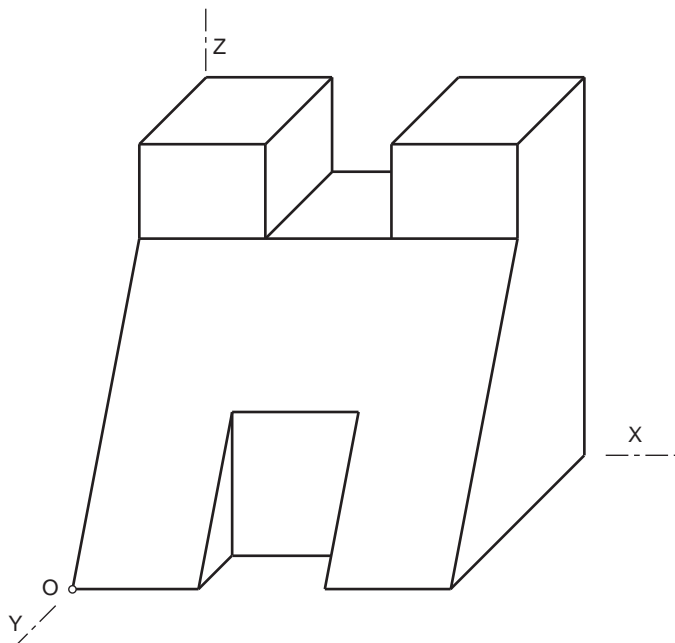

ALUMNO:

ESPECIALIDAD:

NÚMERO:



1

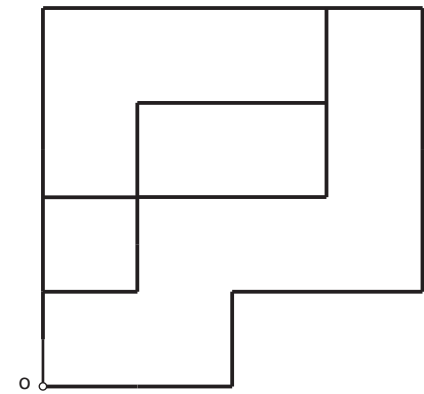
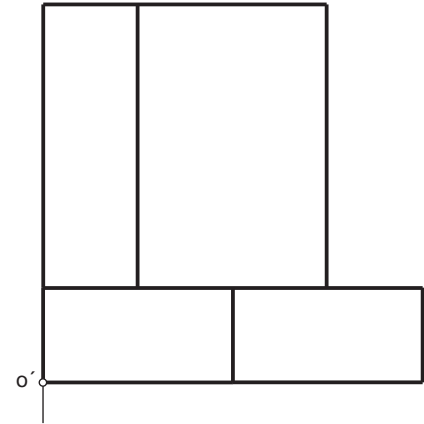
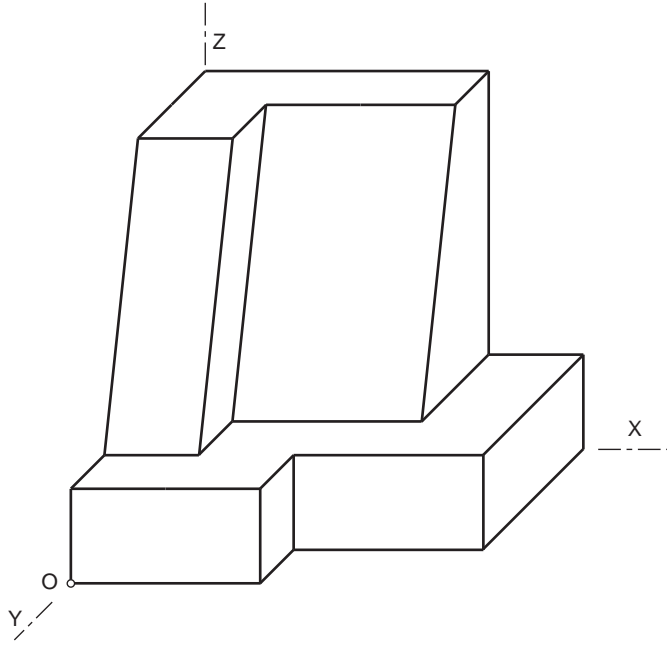

2

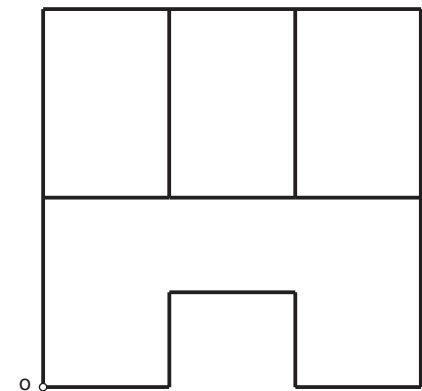
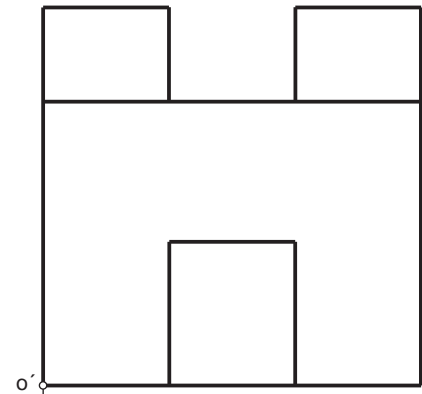
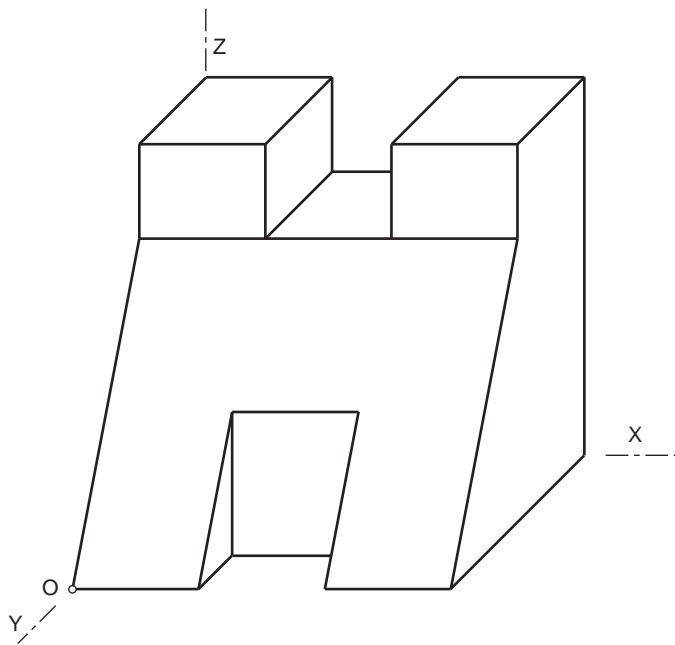



Las figuras dadas están representadas en Perspectiva Caballera a escala 1:1 y con un coeficiente de reducción para el eje Y de 0,5. Dibujarlas a la misma escala en el Sistema Diédrico (Método Directo), tomando como referencia el punto dado O, incluyendo partes vistas y ocultas.

1

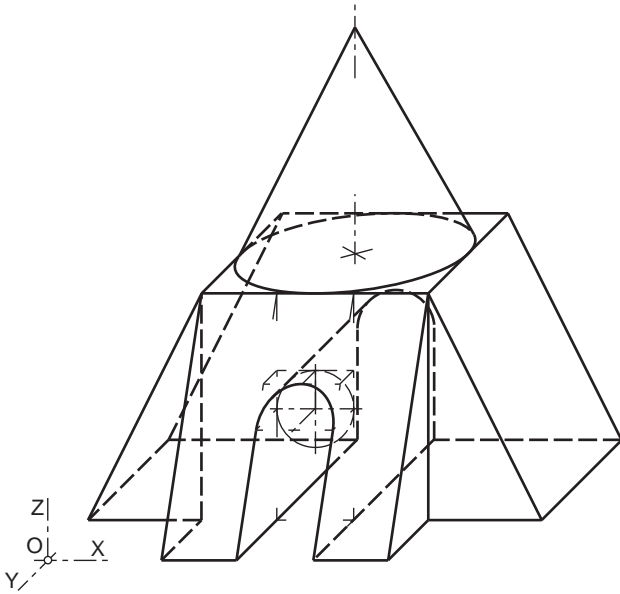

2

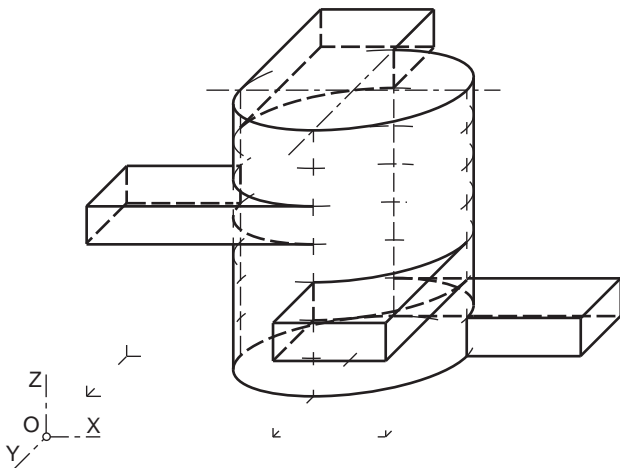

ALUMNO:

ESPECIALIDAD:

NÚMERO:



1

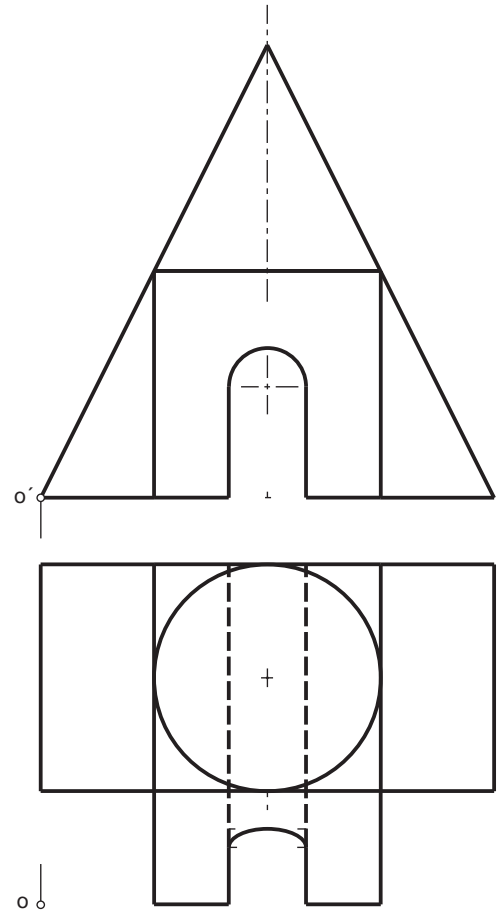
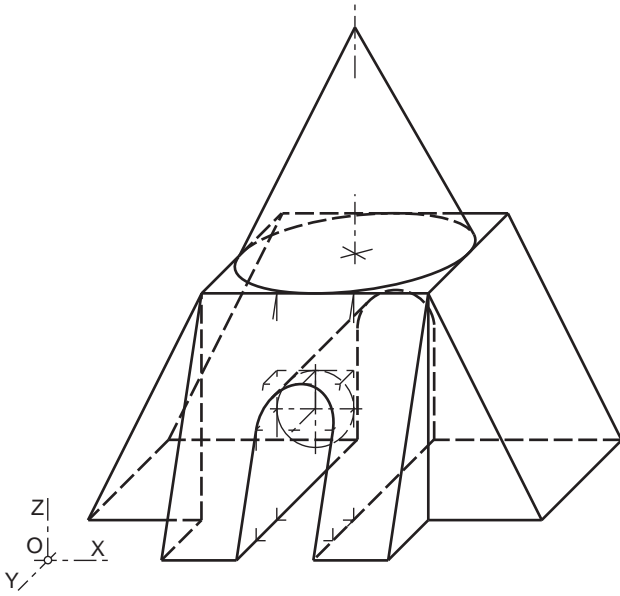

2

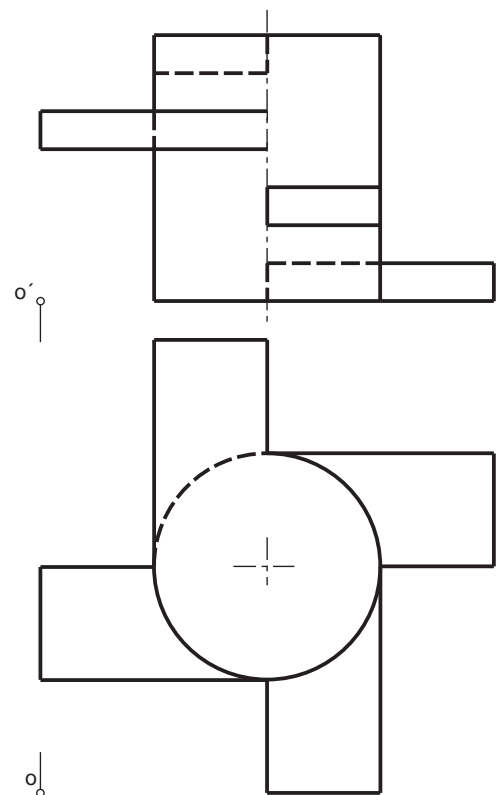
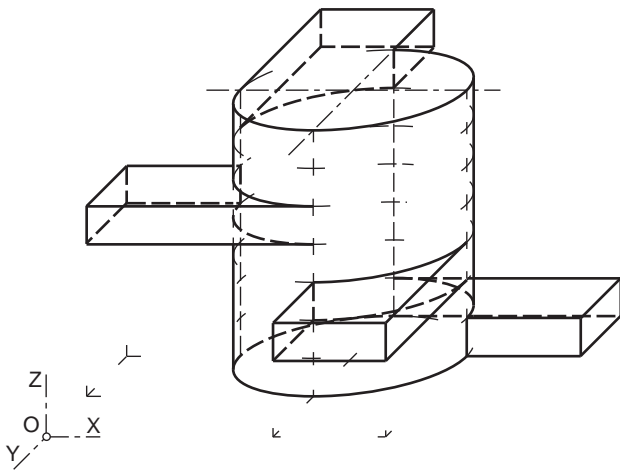



Las figuras dadas están representadas en Perspectiva Caballera a escala 1:1 y con un coeficiente de reducción para el eje Y de 0,5. Dibujarlas a la misma escala en el Sistema Diédrico (Método Directo), tomando como referencia el punto dado O y representando partes vistas y ocultas.

1

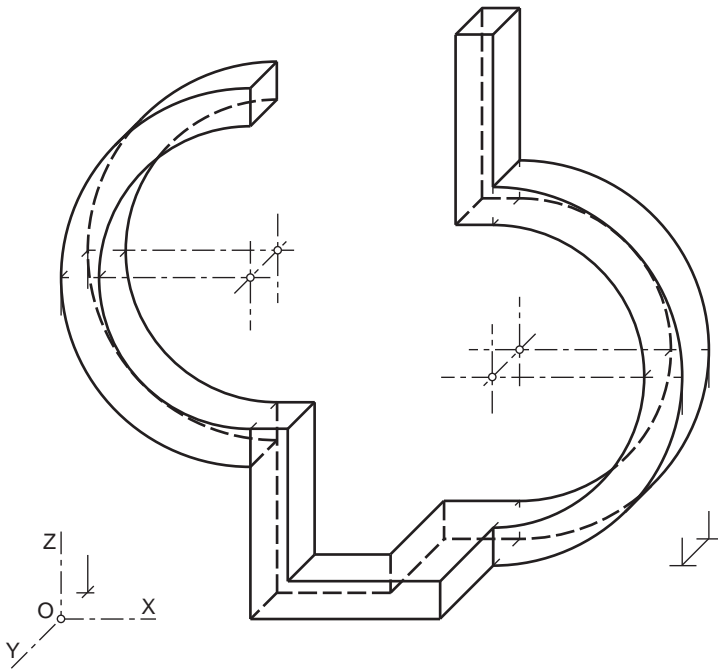

2

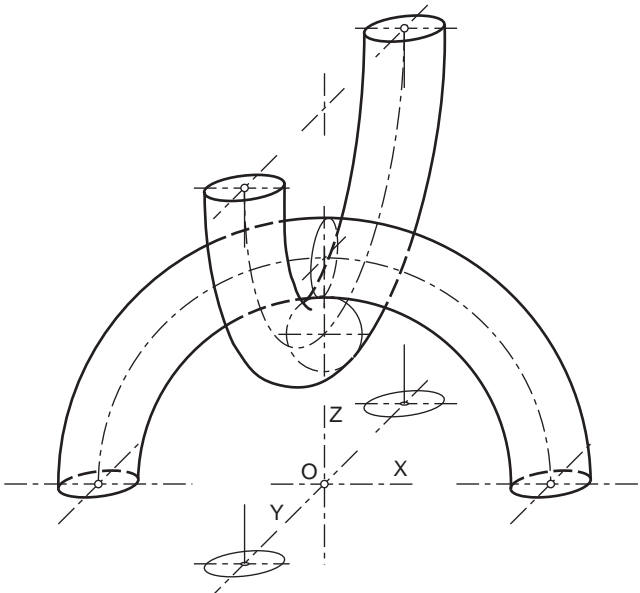



1

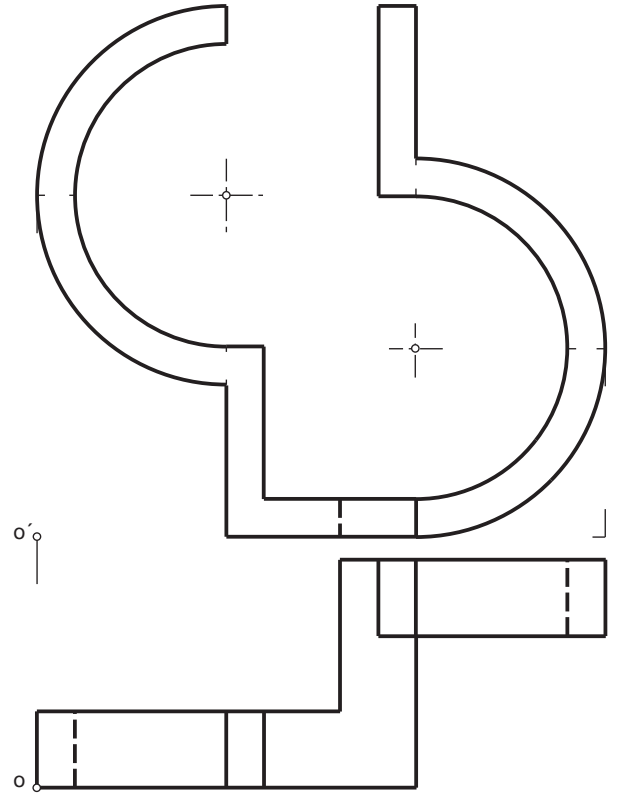
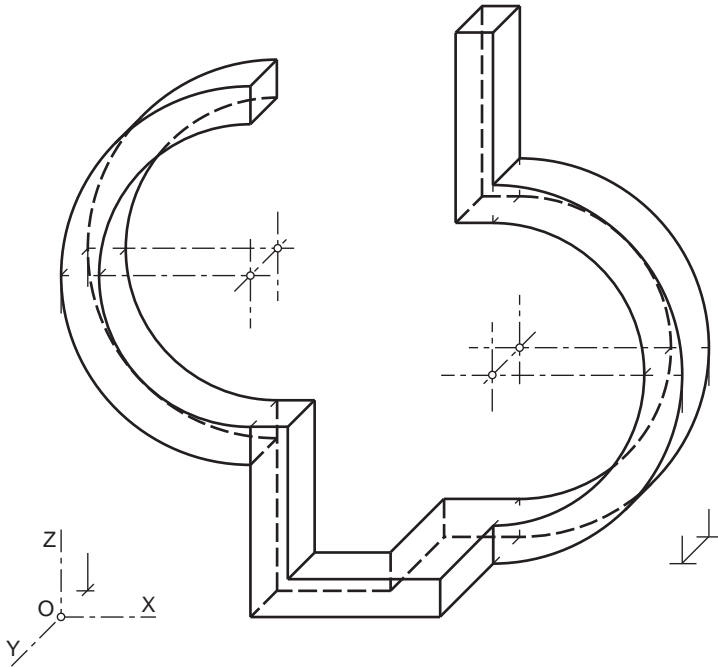

2

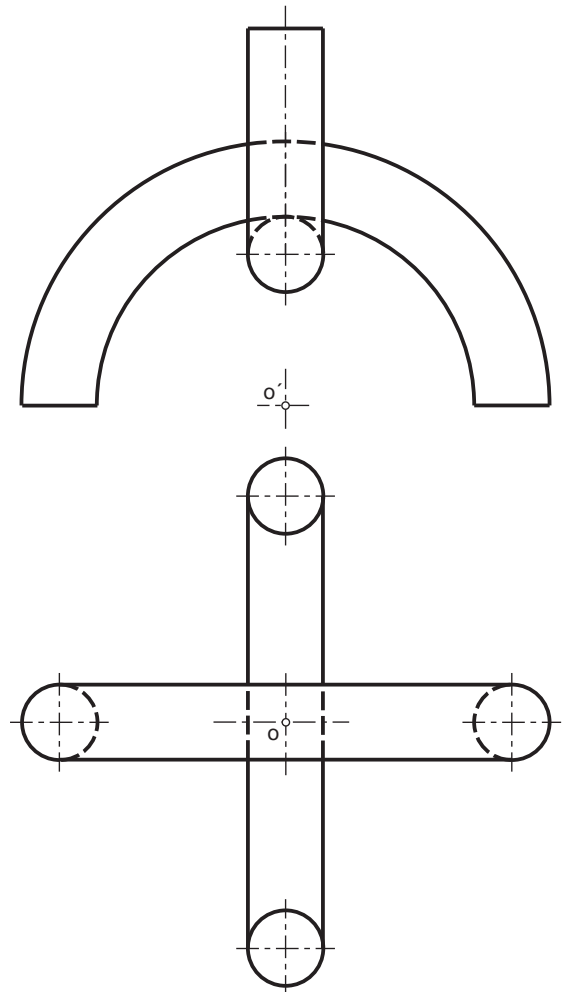
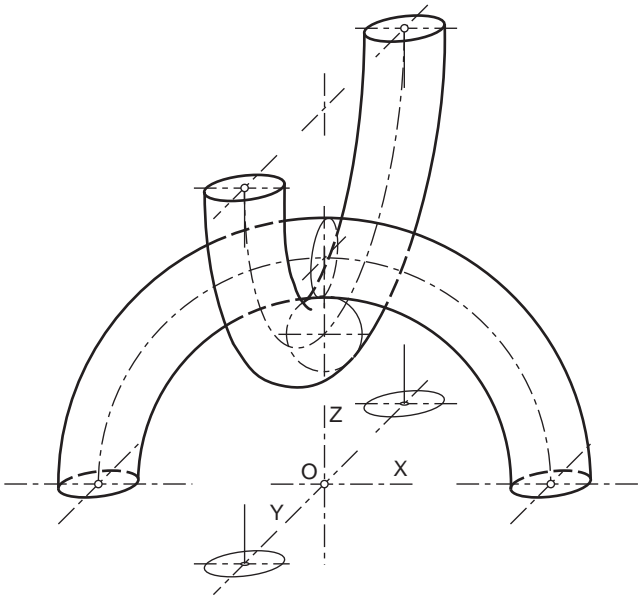



Las figuras dadas están representadas en Perspectiva Caballera a escala 1:1 y con un coeficiente de reducción para el eje Y de 0,5. Dibujarlas a la misma escala en el Sistema Diédrico (Método Directo), tomando como referencia el punto dado O y representando partes vistas y ocultas.

1

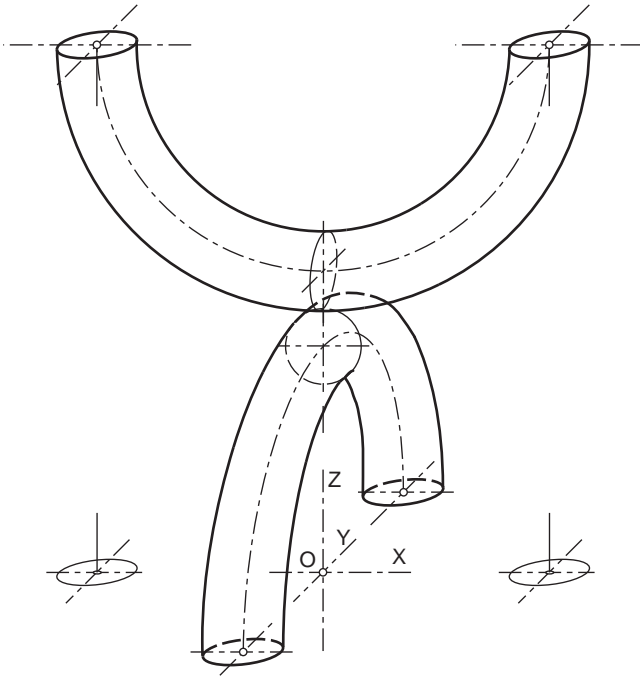

2

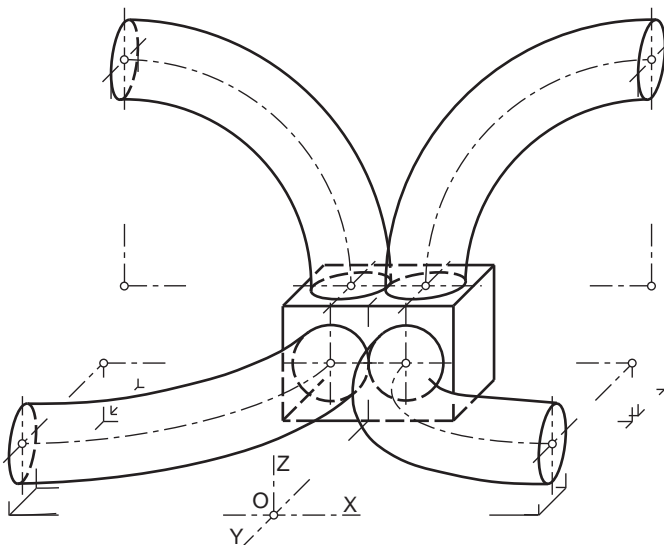



1

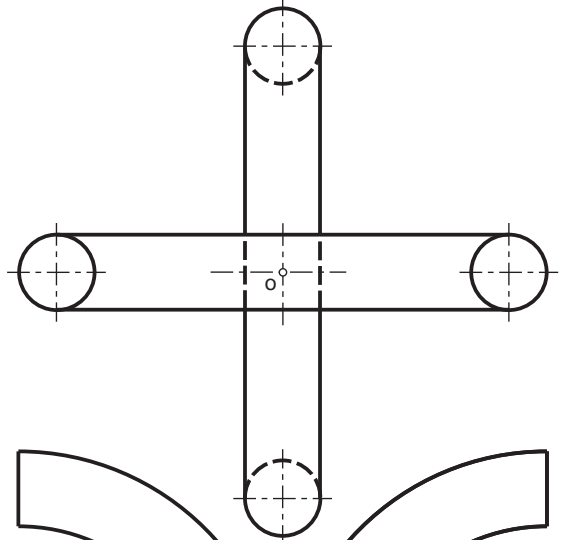
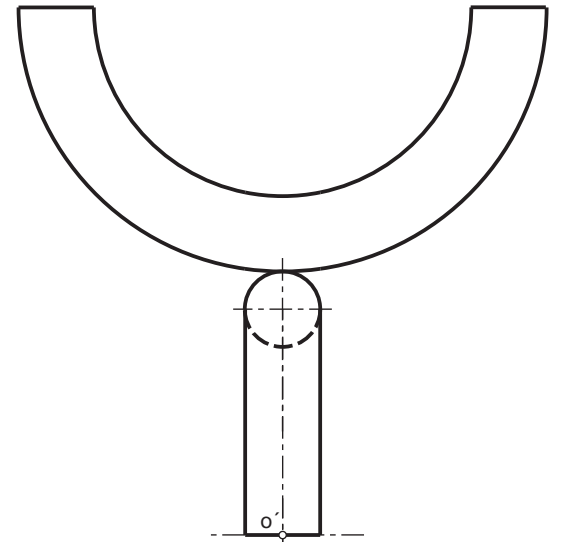
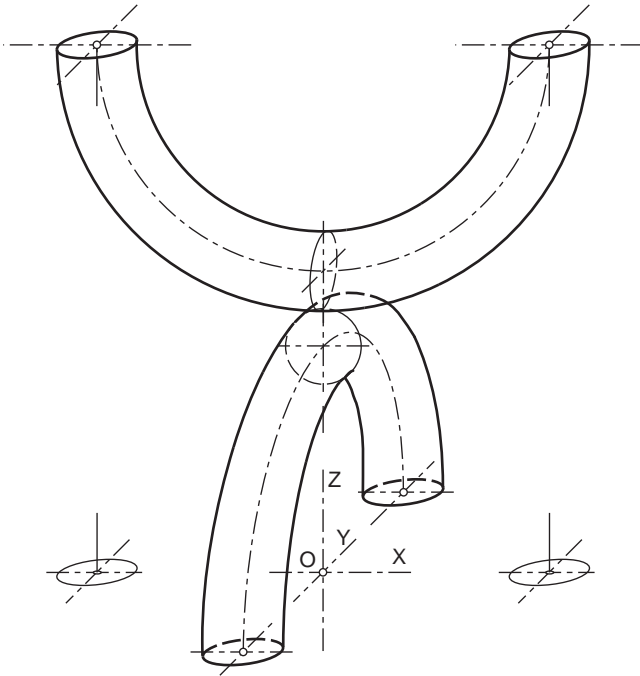

2

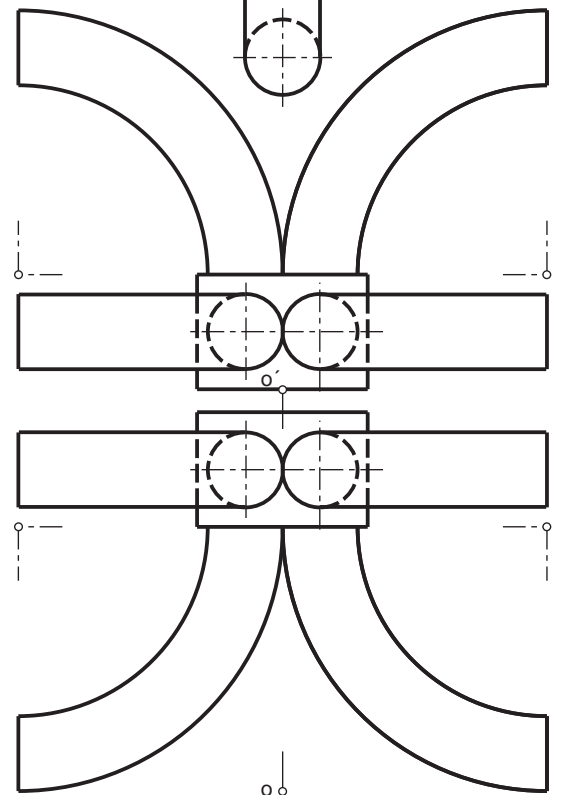
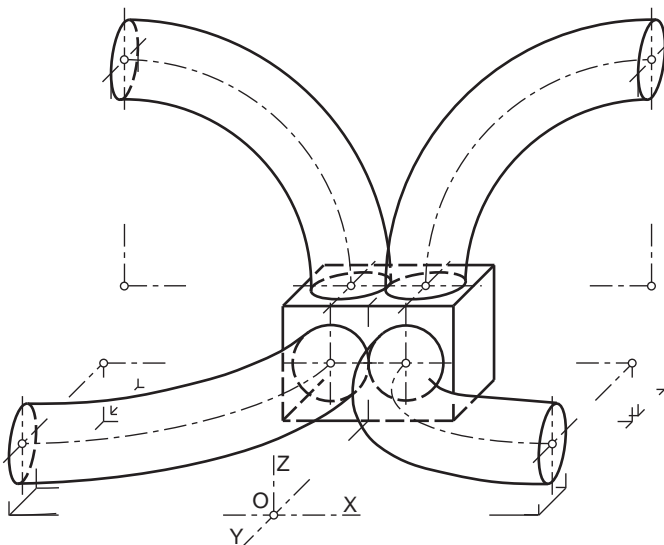



Dibujar el perfil izquierdo de las figuras dadas en planta y alzado, tomando como referencia el punto A que se incluye.

1

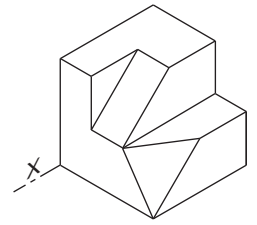
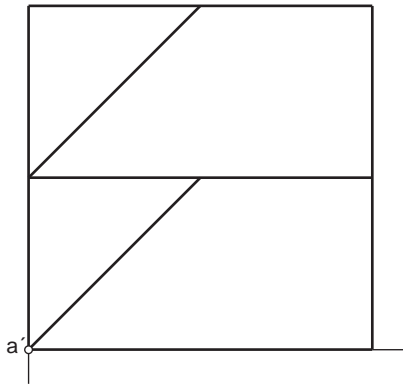

a''

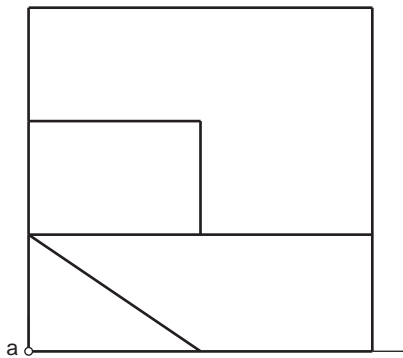

a''

2

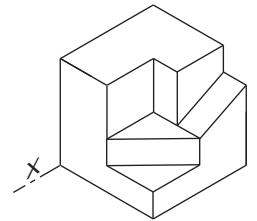
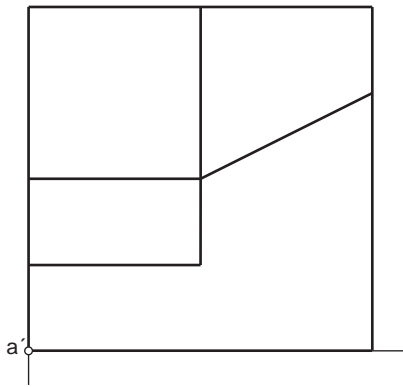

a''

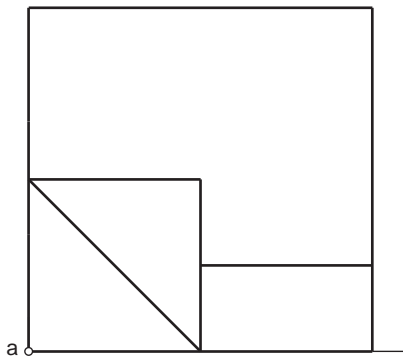

a''

ALUMNO:

ESPECIALIDAD:

NÚMERO:



1

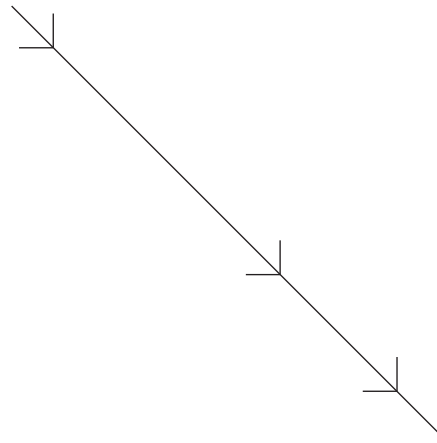
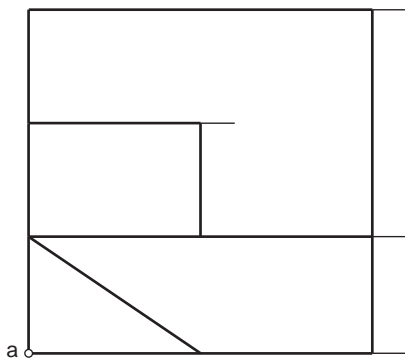
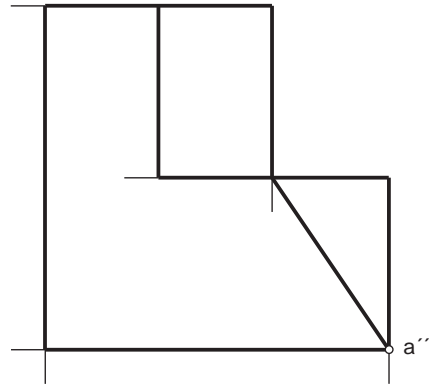
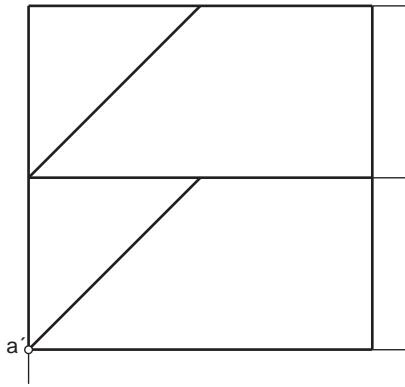

2

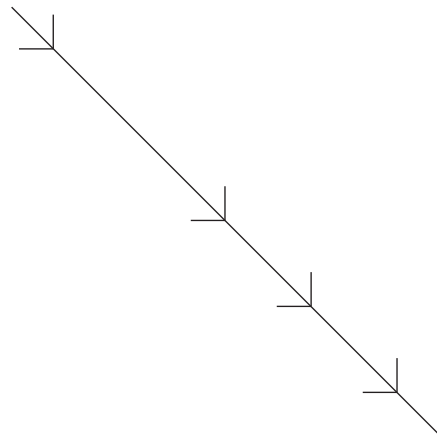
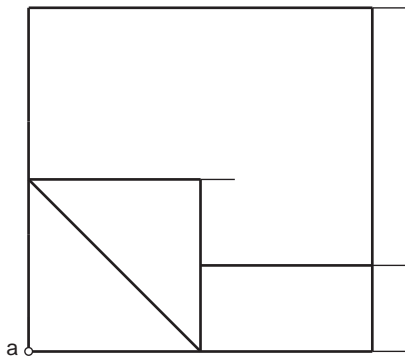
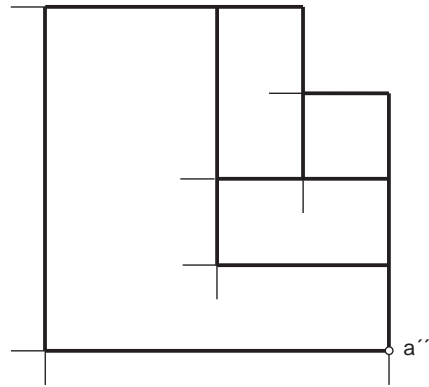
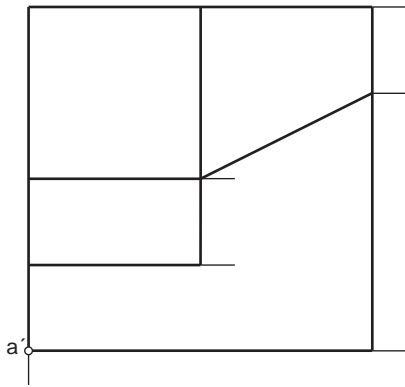



Dibujar el perfil izquierdo de las figuras dadas en planta y alzado, tomando como referencia el punto A que se incluye.

1

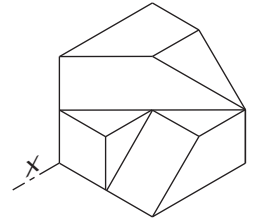
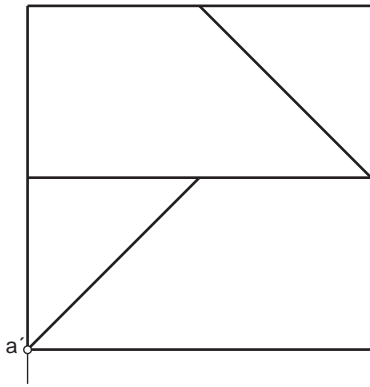

a''

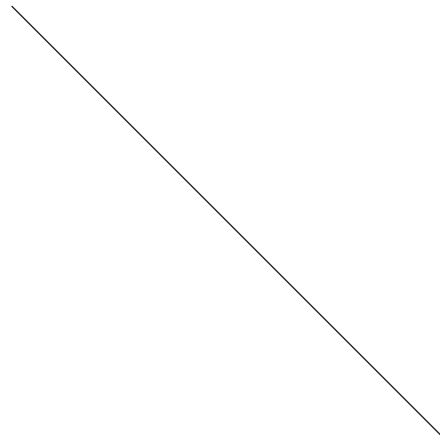
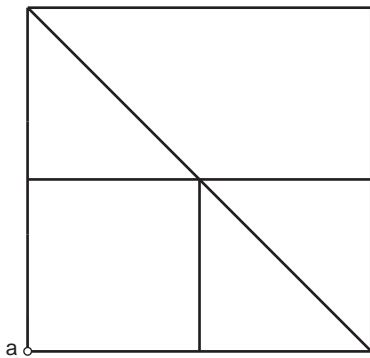

2

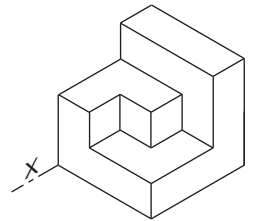
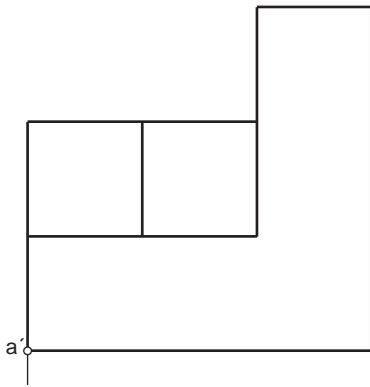

a''

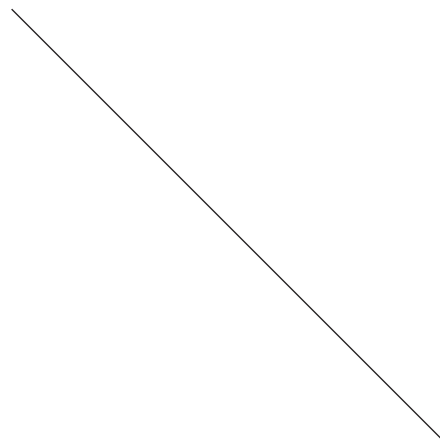
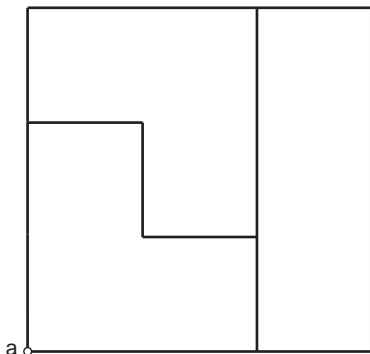

ALUMNO:	ESPECIALIDAD:	NÚMERO:
---------	---------------	---------



1

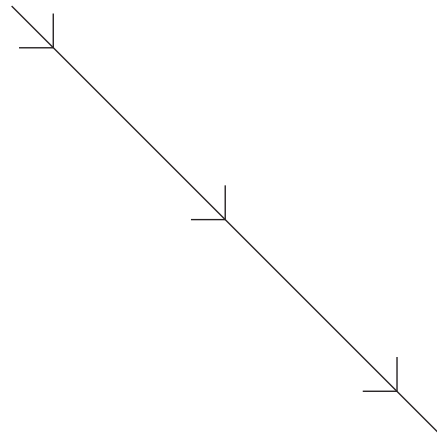
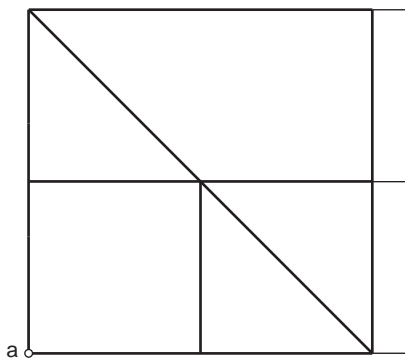
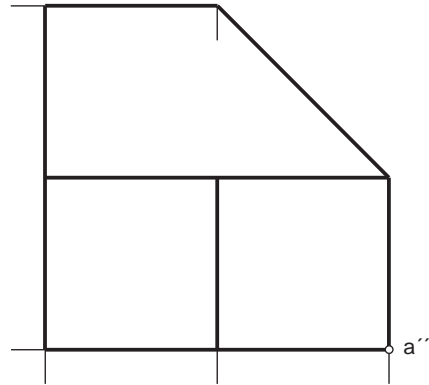
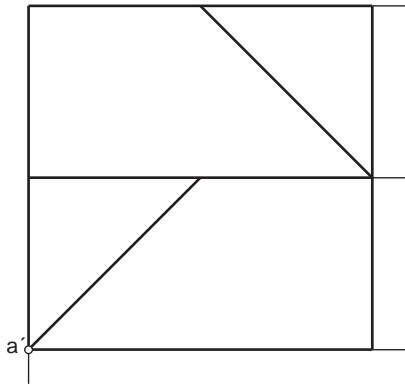

2

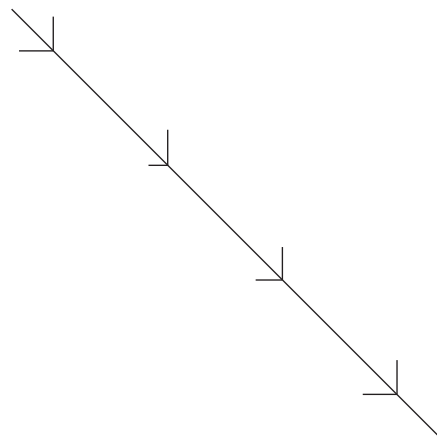
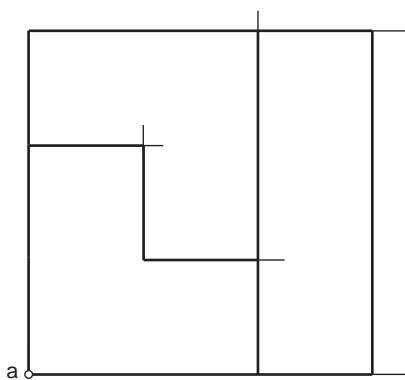
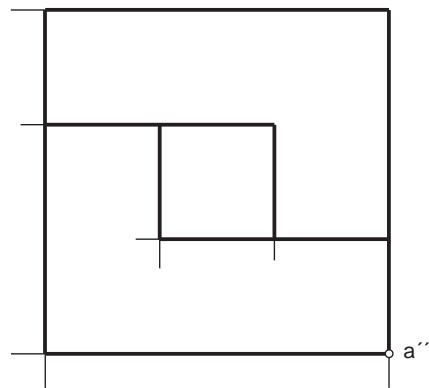
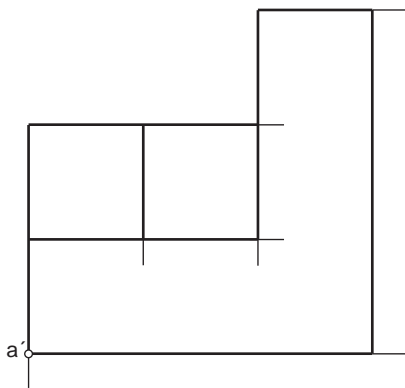



Dibujar el perfil izquierdo de las figuras dadas en planta y alzado, tomando como referencia el punto A que se incluye.

1

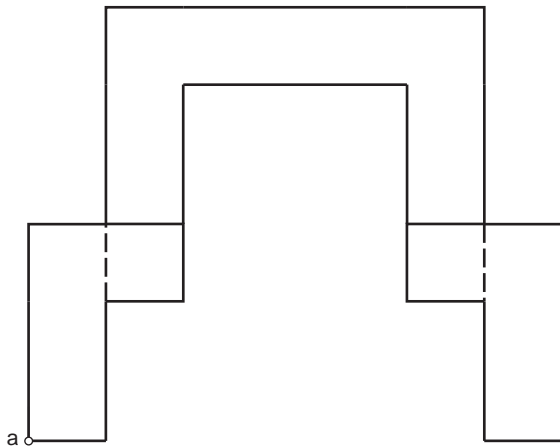
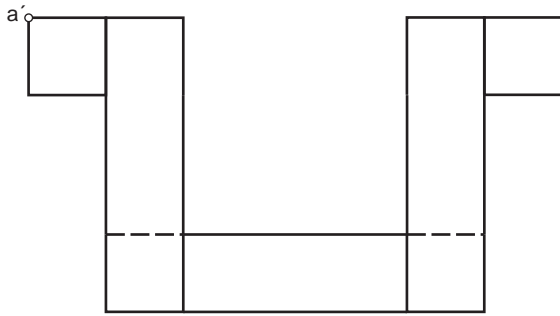

2

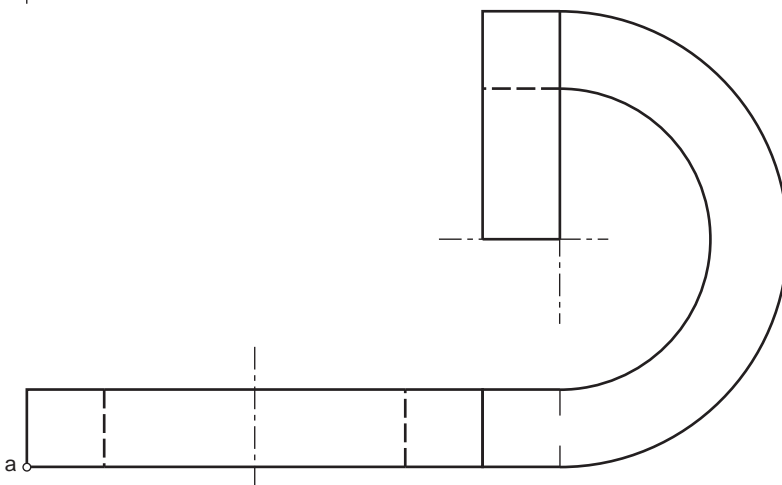
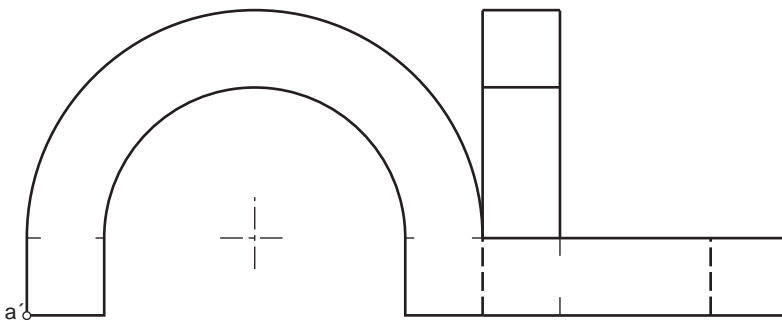

ALUMNO:

ESPECIALIDAD:

NÚMERO:



1

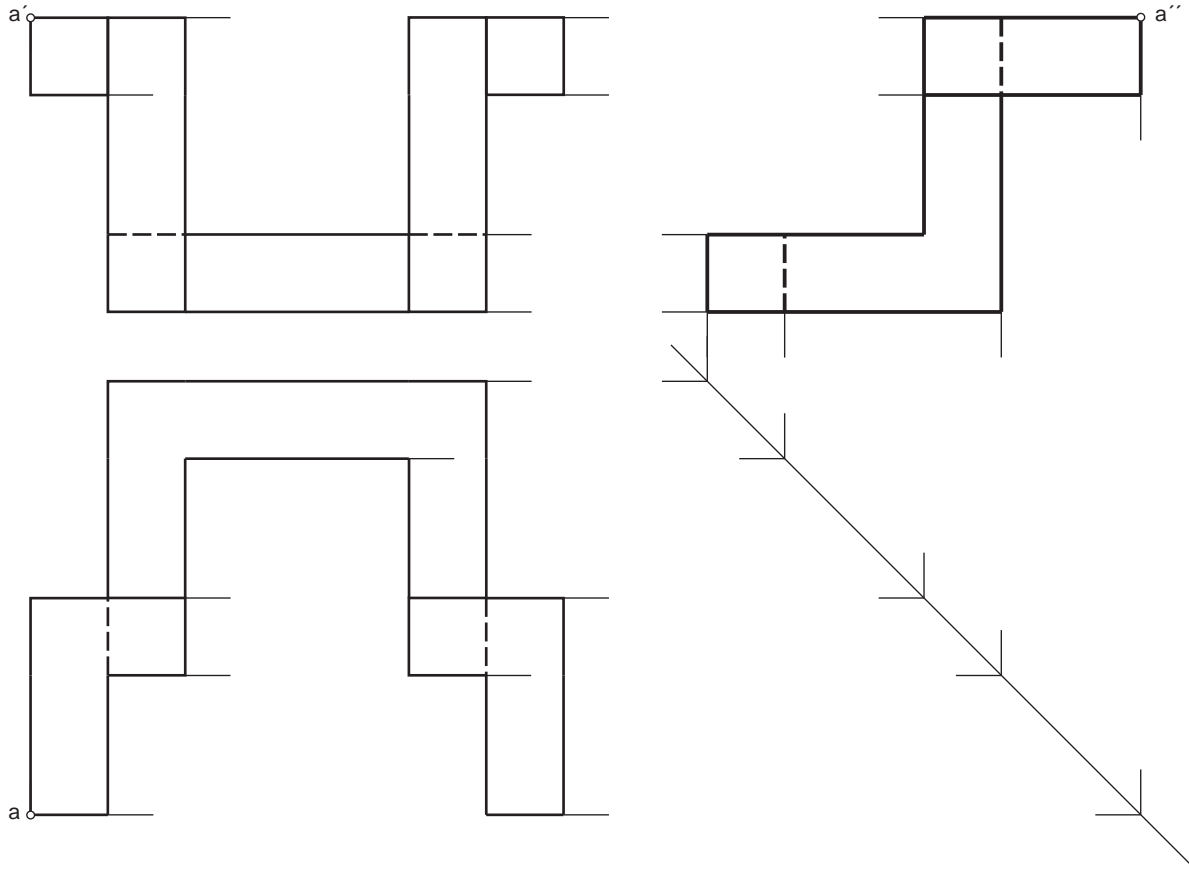

2

