

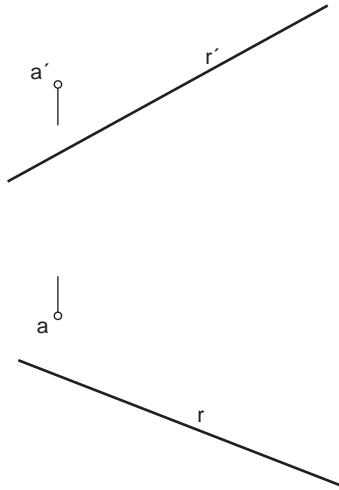

Dibujar las rectas que siendo paralelas a las dadas, contengan a los respectivos puntos A que se incluyen.

1



2

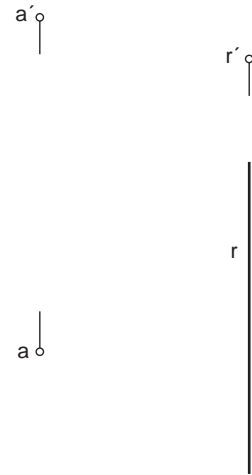

3

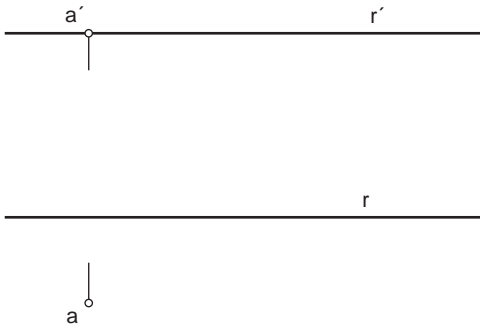

4

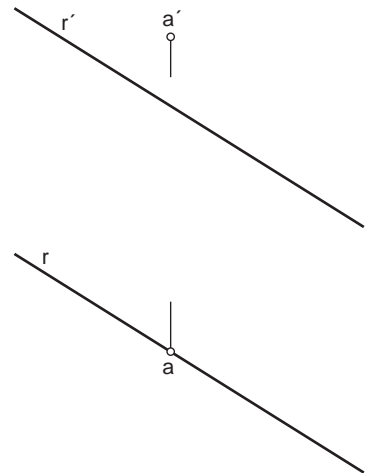

5

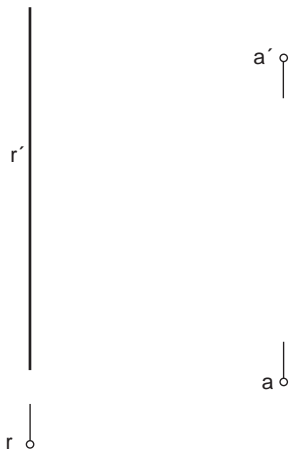

6



ALUMNO:

ESPECIALIDAD:

NÚMERO:



1

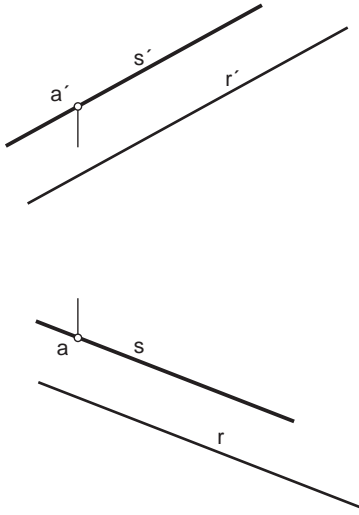

2

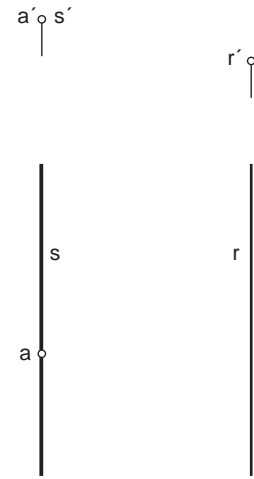

3

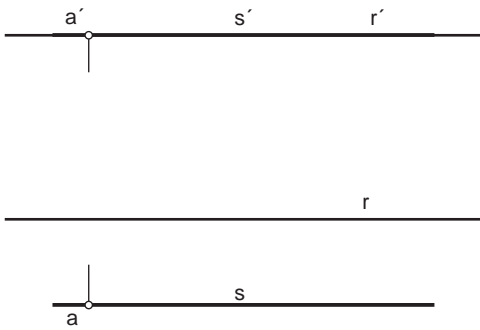

4

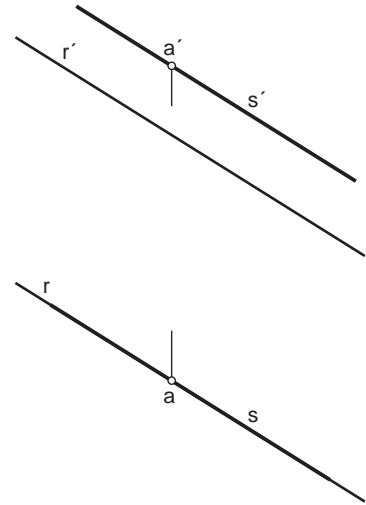

5

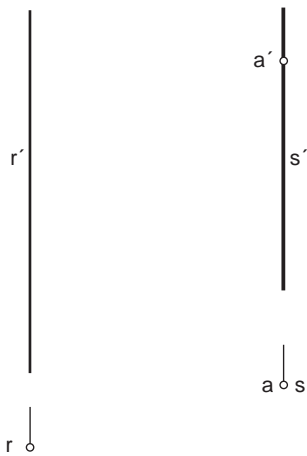

6

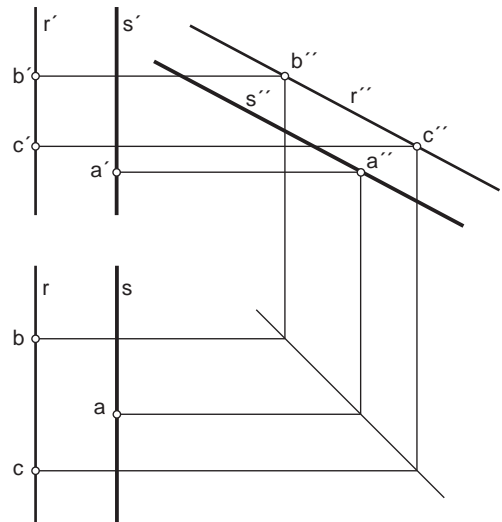



Representar las rectas que, siendo paralelas a los planos que se dan, contengan a los puntos D incluidos y presenten las posiciones indicadas en cada caso.

1

Recta de punta.

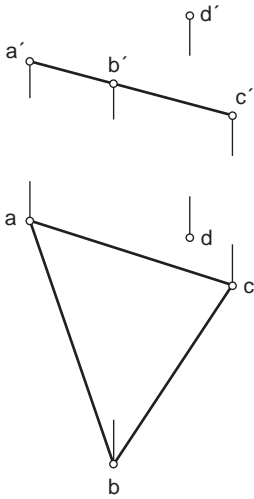

2

Recta horizontal.

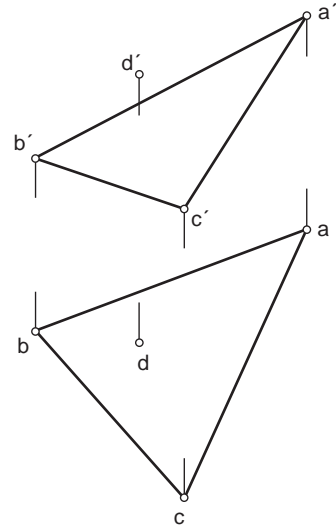

3

Recta paralela al 1º P.B.

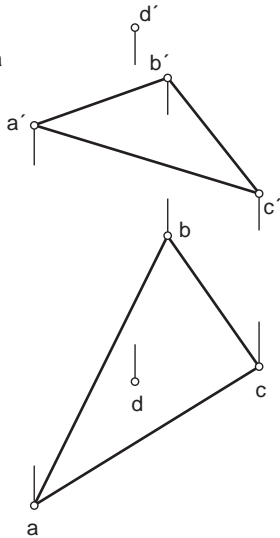

4

Recta frontal.

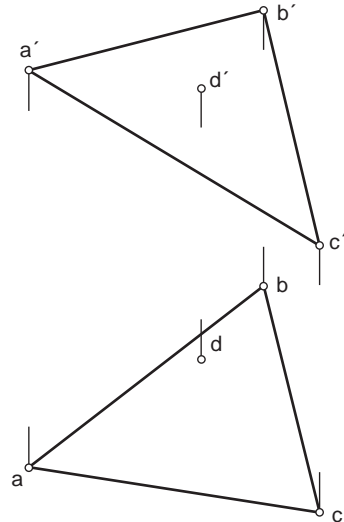

5

Recta paralela a la L.T.

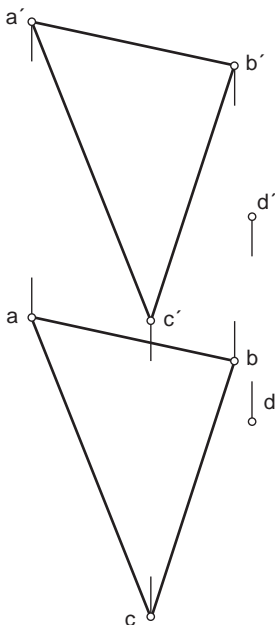

6

Recta paralela al 2º P.B.

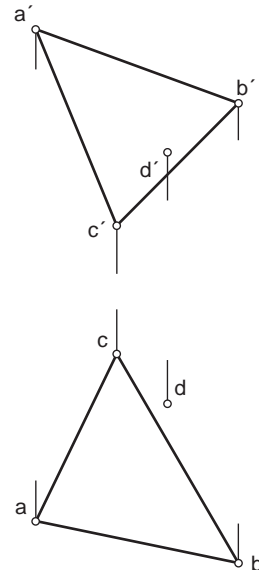

ALUMNO:

ESPECIALIDAD:

NÚMERO:



1

Recta de punta.

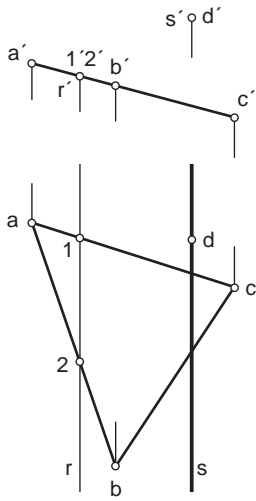

2

Recta horizontal.

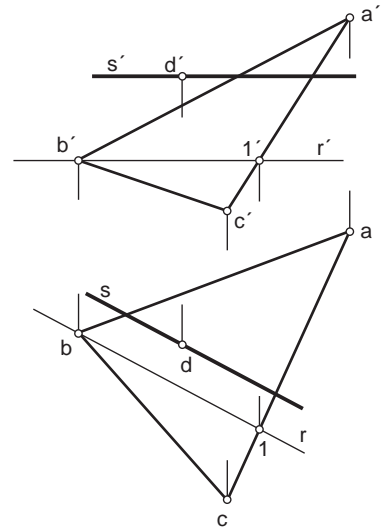

3

Recta paralela al 1º P.B.

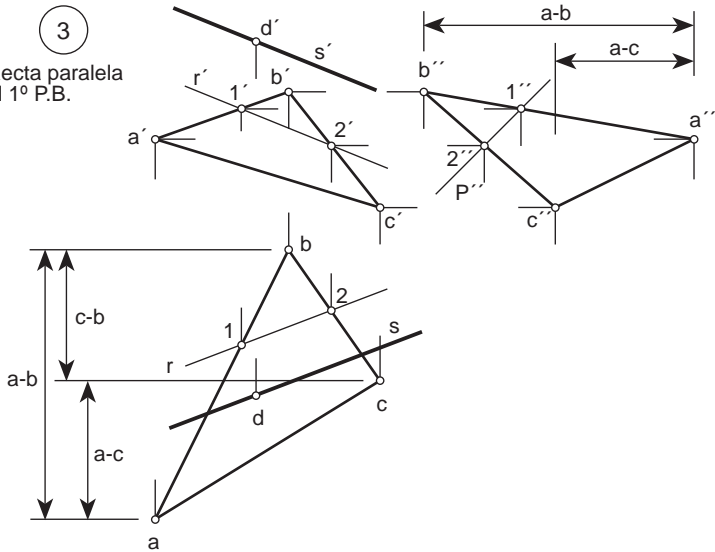

4

Recta frontal.

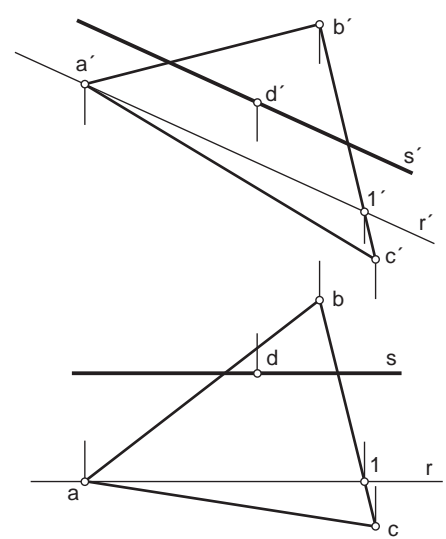

5

Recta paralela a la L.T.

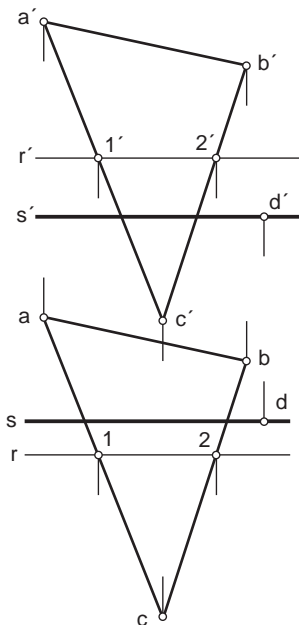

6

Recta paralela al 2º P.B.

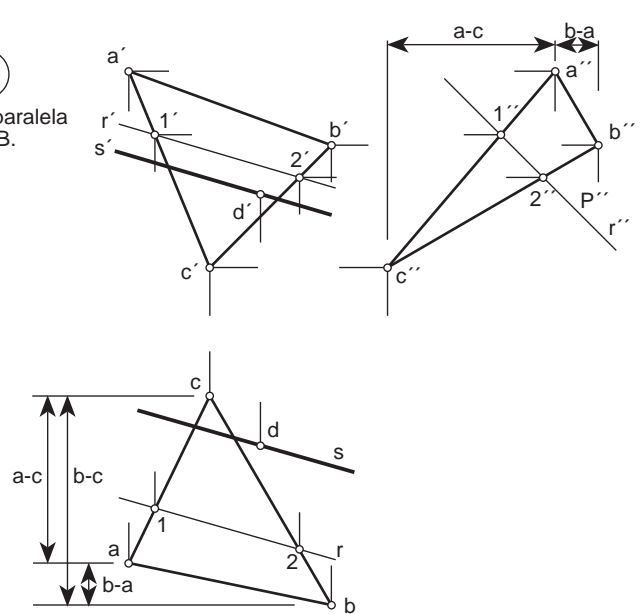



Dibujar planos triangulares cualesquiera, que sean paralelos a los dados y que contengan a los puntos G que se incluyen.

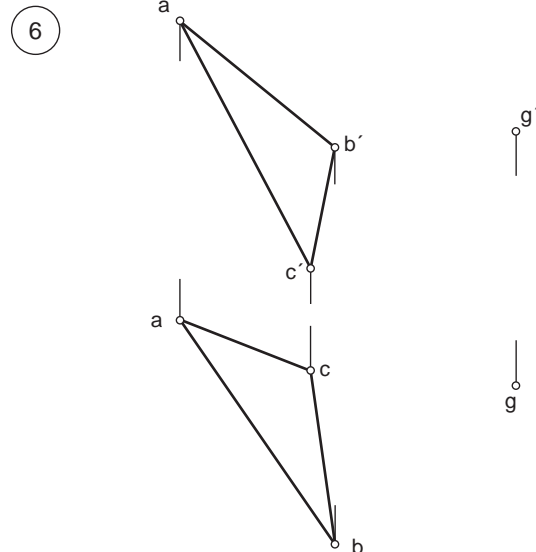
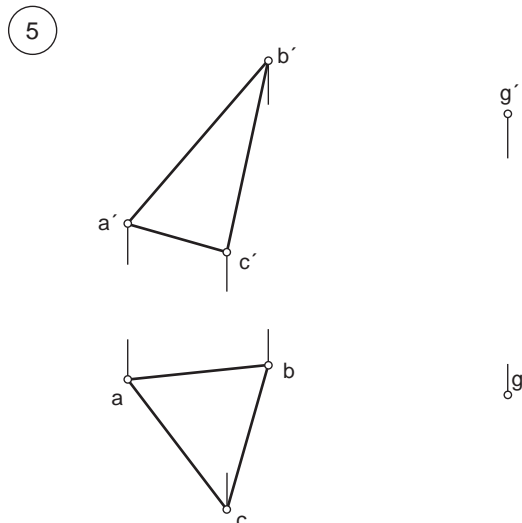
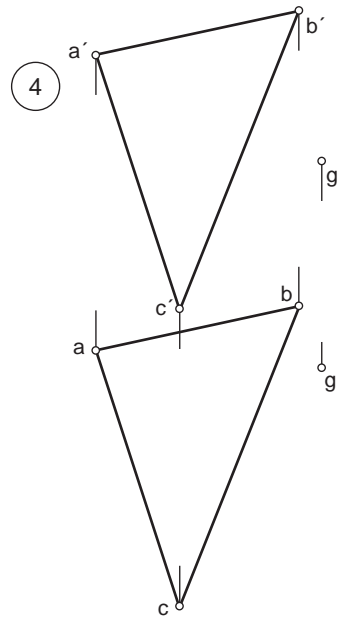
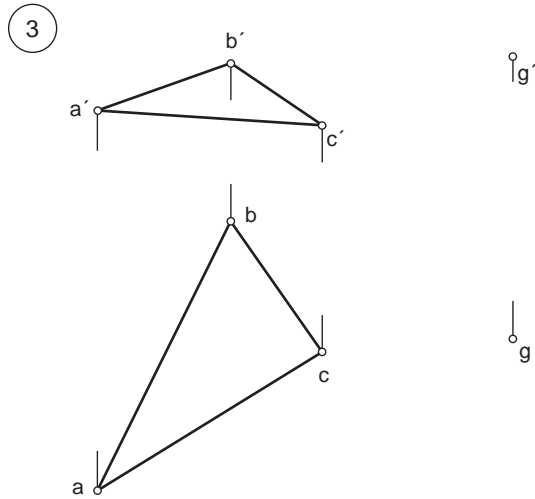
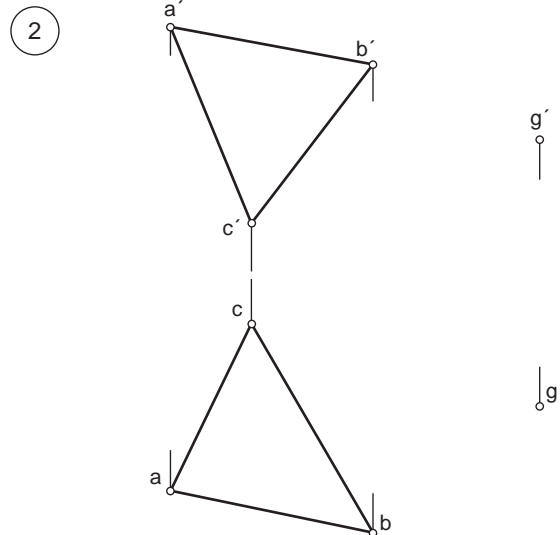
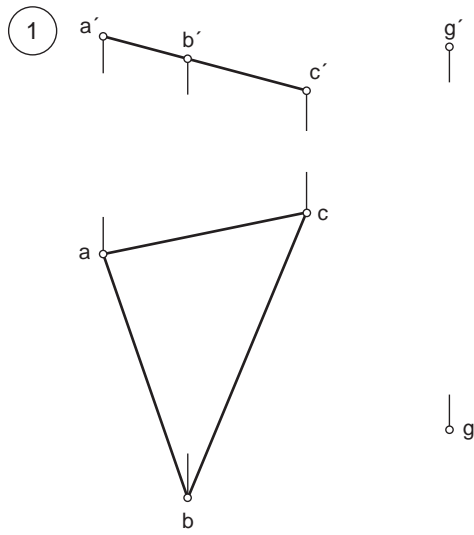

ALUMNO:	ESPECIALIDAD:	NÚMERO:
---------	---------------	---------

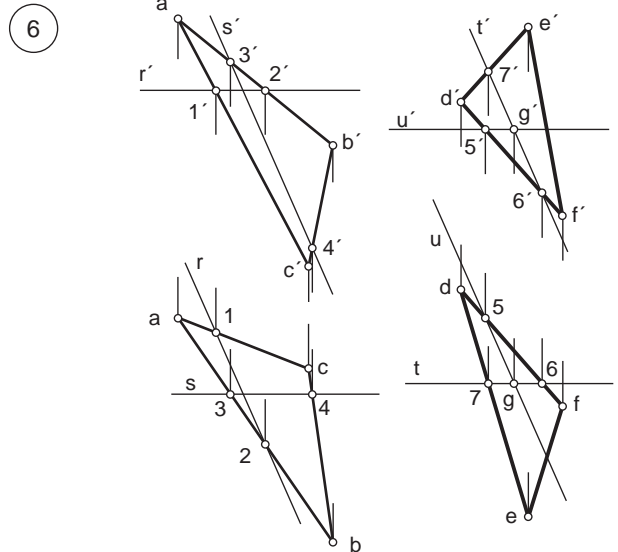
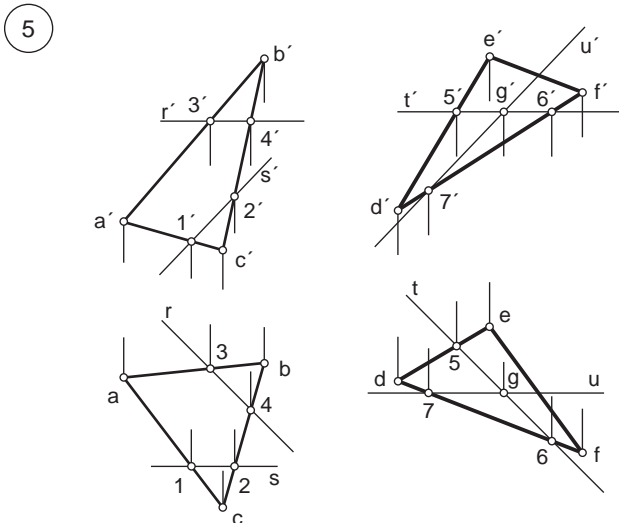
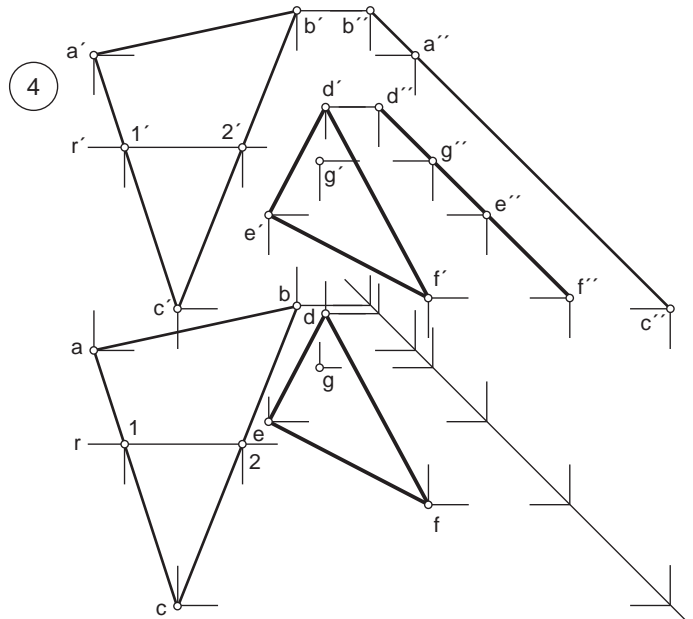
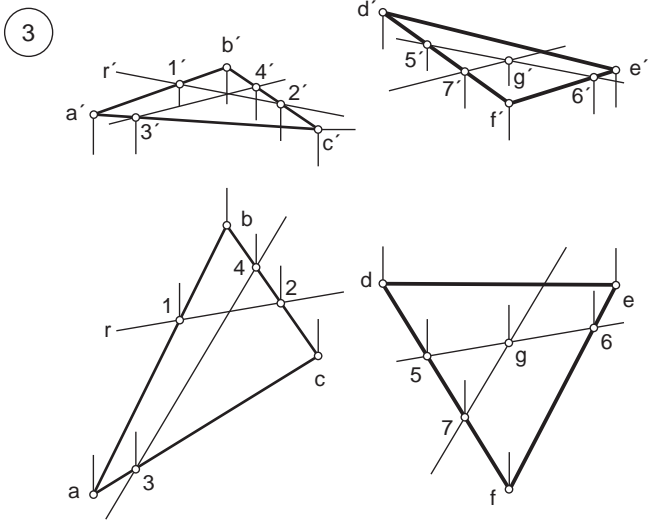
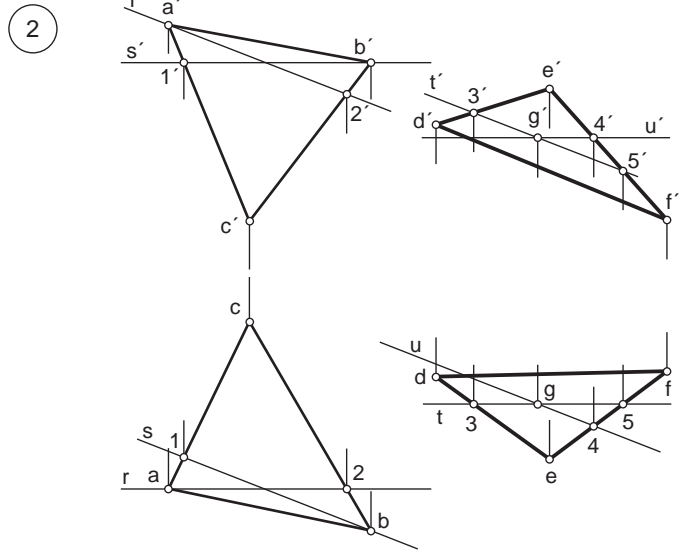
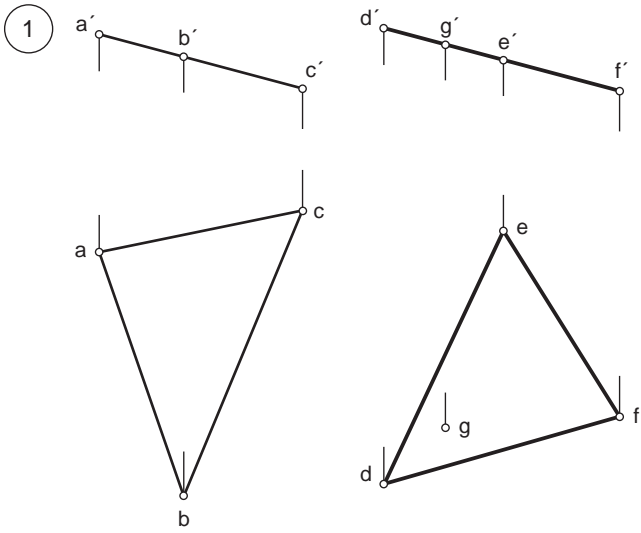



Desde el punto 3, que pertenece a la superficie de la figura C, se quiere construir una línea paralela a la 1-2, que une las superficies de las figuras A y B. Hallar el punto de intersección de dicha línea con la cara tramada de la figura D, representando las partes vistas y ocultas de la misma.

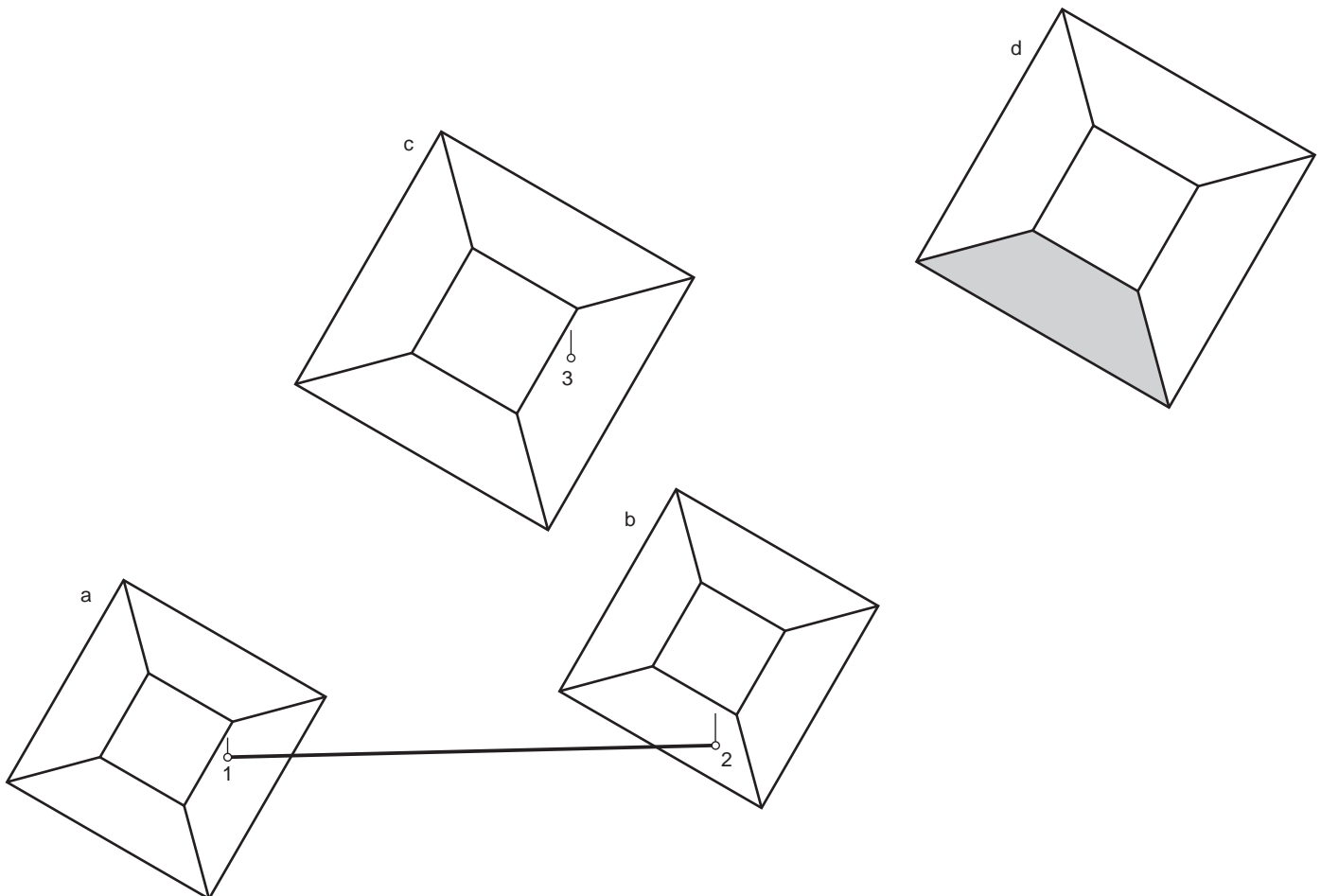
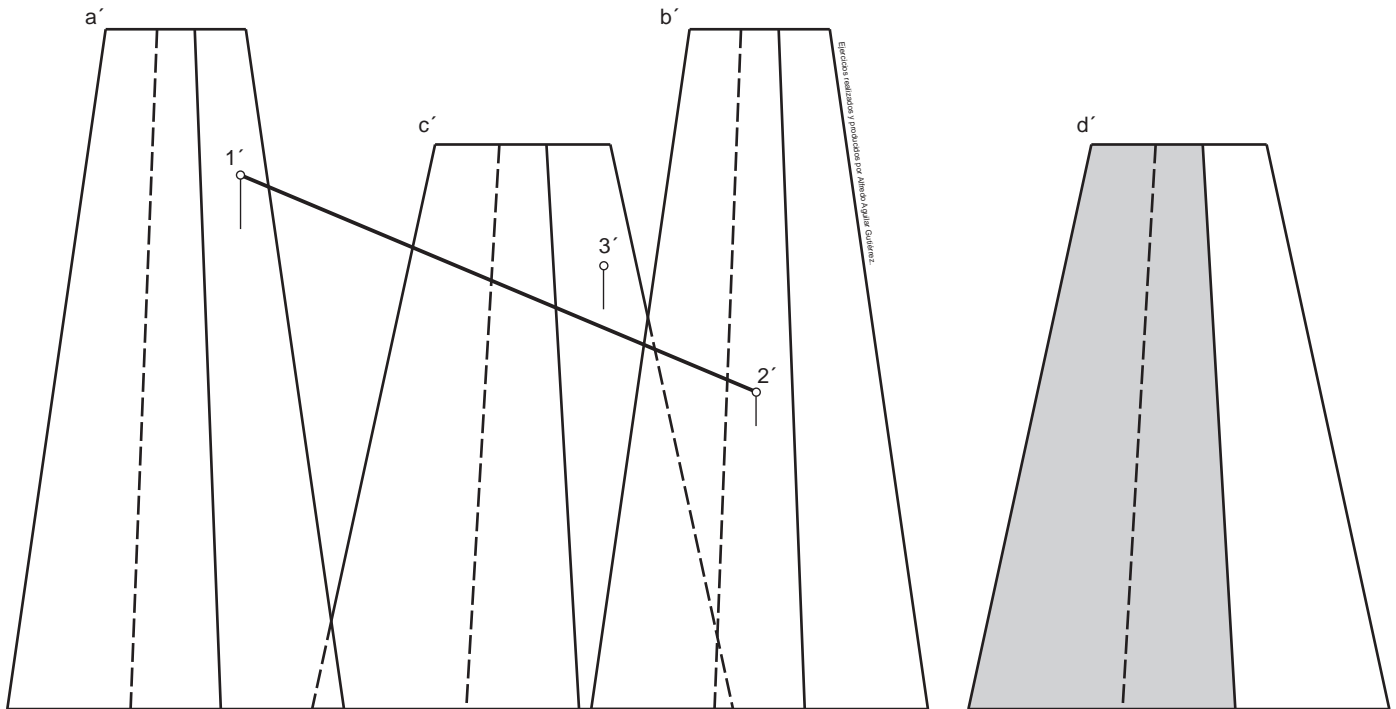

ALUMNO:

ESPECIALIDAD:

NÚMERO:



A-B, A-C y A-D son las tres aristas, convergentes en el vértice A, de un paralelepípedo. Dibujar dicho poliedro y repetir la operación con las aristas A₁-B₁, A₁-C₁ y A₁-D₁ de un segundo paralelepípedo. Representar las partes vistas y ocultas de las dos figuras considerándolas opacas.

c'

b'

a'

b'₁

d'

d'₁

c'₁

a'₁

b

d

d₁

c

a

a₁

c₁

b₁

ALUMNO:

ESPECIALIDAD:

NÚMERO:

